



# MODEL S-4000 CAED Omron

**CUT AFTER EDGE**

## PARTS AND SERVICE MANUAL

MACHINE SERIAL No.:

**PART NUMBER 97.2430.1.001**

This manual is valid from the machine serial number M241429



## LIMITED WARRANTY ON NEW AMF REECE EQUIPMENT

### Warranty provisions:

A ninety (90) day limited service labor warranty to correct defects in installation, workmanship, or material without charge for labor. This portion of the warranty applies to machines sold as "installed" only.

A one (1) year limited material warranty on major component parts to replace materials with defects. Any new part believed defective must be returned freight prepaid to AMF Reece, Inc. for inspection. If, upon inspection, the part or material is determined to be defective, AMF Reece, Inc. will replace it without charge to the customer for parts or material.

Service labor warranty period shall begin on the completed installation date. Material warranty shall begin on the date the equipment is shipped from AMF Reece, Inc.

### Exclusions:

Excluded from both service labor warranty and material warranty are: (1) Consumable parts which would be normally considered replaceable in day-to-day operations. These include parts such as needles, knives, loopers and spreaders. (2) Normal adjustment and routine maintenance. This is the sole responsibility of the customer. (3) Cleaning and lubrication of equipment. (4) Parts found to be altered, broken or damaged due to neglect or improper installation or application. (5) Damage caused by the use of non-Genuine AMF Reece parts. (6) Shipping or delivery charges.

There is no service labor warranty for machines sold as "uninstalled".

Equipment installed without the assistance of a certified technician (either an AMF Reece Employee, a Certified Contractor, or that of an Authorized Distributor) will have the limited material warranty only. Only the defective material will be covered. Any charges associated with the use of an AMF Reece Technician or that of a Distributor to replace the defective part will be the customer's responsibility.

NO OTHER WARRANTY, EXPRESS OR IMPLIED, AS TO DESCRIPTION, QUALITY, MERCHANTABILITY, and FITNESS FOR A PARTICULAR PURPOSE, OR ANY OTHER MATTER IS GIVEN BY SELLER OR SELLER'S AGENT IN CONNECTION HEREWITH. UNDER NO CIRCUMSTANCES SHALL SELLER OR SELLER'S AGENT BE LIABLE FOR LOSS OF PROFITS OR ANY OTHER DIRECT OR INDIRECT COSTS, EXPENSES, LOSSES OR DAMAGES ARISING OUT OF DEFECTS IN OR FAILURE OF THE EQUIPMENT OR ANY PART THEREOF.

### WHAT TO DO IF THERE IS A QUESTION REGARDING WARRANTY

If a machine is purchased through an authorized AMF Reece, Inc. distributor, warranty questions should be first directed to that distributor. However, the satisfaction and goodwill of our customers are of primary concern to AMF Reece, Inc. In the event that a warranty matter is not handled to your satisfaction, please contact the appropriate AMF Reece office:

Prostejov, Czech Republic  
Phone: (+420) 582-309-286  
Fax: (+420) 582-360-608  
e-mail: [service@amfreece.cz](mailto:service@amfreece.cz)



# Warranty Registration Card

*(Please Fax or Mail immediately after installation)*

**Note: All Warranty Claims Void, unless Registration Card on file at AMF Reece HQ**

Machine model number:

*(S100, S101, S104, S105, S 311, Deco, S4000 , EBS Mark II, ES505, etc)*

Manufacturer's serial or production number:

## **Installation Site Information:**

Customer's Name:

Customer's Mailing Address:

Customer's Telephone Number:

Supervising Mechanic's or Technician's Name:

Signature of Supervising Technician:

AMF Reece Technician's Name:

AMF Reece Technician's Signature:

Type of garment produced at this location?

Average Daily Production Expected from this machine?

*(number of buttonholes, jackets sewn, pants produced, buttons sewn, etc)*

Any special requirements required at this location?

What other AMF Reece Machines are at this location?

How can we serve you better?

**Tovární 837, 798 11 Prostejov, Czech Republic**

**Fax: +420 582 360 606, e-mail: [service@amfreece.cz](mailto:service@amfreece.cz), website: [www.amfreece.com](http://www.amfreece.com)**



## TABLE OF CONTENTS

---

### A - INTRODUCTION

1. Basic information .....	1-1
2. Safety device and labels .....	1-2
3. General machine parts description .....	1-3
4. Specifications .....	1-4
5. Instructions for operator safety and maintenance .....	1-5
6. Special accessories .....	1-6

### B - MACHINE ASSEMBLY

1. Content of the shipping box .....	1-8
2. Accessories .....	1-8
3. Power and air connection .....	1-9
4. Head pneumatic .....	1-10
5. Installation of thread holder .....	1-11

### C - PROPER APPLICATION

1. Power Up/ Home position .....	1-12
2. Needle installation .....	1-13
3. Threading .....	1-14

### D - MACHINE CONTROLS

1. Progress of sewing .....	1-15
2. Operator control panel push buttons and switches .....	1-16
3. Control panel information .....	1-17
4. The programming menu .....	1-17
5. Tests .....	1-20
6. Program version .....	1-22
7. Schema of programming .....	1-23
8. Parameter checklist .....	1-24

### E - MACHINE ADJUSTMENTS

1. Machine home position .....	1-25
2. Adjustment of the shifter .....	1-25
3. Principles for machine adjustment .....	1-25
4. Needle bar .....	1-26
5. Bite .....	1-27
6. Feeding .....	1-29
7. Clutch .....	1-30
8. Stitch Density .....	1-30

## TABLE OF CONTENTS

---

### E - MACHINE ADJUSTMENTS

9. Looper adjustments .....	1-31
10. Home position of the clamp plate .....	1-34
11. Clamp plate adjustment .....	1-35
12. Trimming mechanism adjustment .....	1-35
13. Adjustment of the clamp plate change-over .....	1-36
14. Adjustment of machine head clamping foot .....	1-37
15. Thread draw off .....	1-37
16. Thread tension .....	1-38
17. Thread trimming .....	1-38
18. Cuts-off blow off .....	1-39
19. Thread blow off (special accessory) .....	1-40
20. Adjustment of stop sensor position .....	1-40
21. Replacement of the belt .....	1-41
22. Protection during voltage fluctuation (special accessory) .....	1-42
23. Optical sensor - Adjustment .....	1-43

### F - MACHINE MAINTENANCE

1. Cleaning and maintenance of the machine .....	1-44
2. List of regular services .....	1-46
3. Schema of group lubrication .....	1-47
4. Machine lubrication .....	1-48
5. Disposal measures .....	1-50

### G - PNEUMATIC DIAGRA

Pneumatic diagram .....	1-51
-------------------------	------

### H - ELECTRICAL DIRAGRAM

Electrical diagram .....	1-52
--------------------------	------

## A - INTRODUCTION

---

### 1. BASIC INFORMATION

The sewing machines S-4000 CAED are designed and produced to be very reliable. Important design goals have been achieved to provide a safe machine that is simple and inexpensive to maintain.

The patented rotary needle bar shaft drive, a major benefit, delivers longer needle bar life. The added benefits of lower vibration and less noise, translate into less operator fatigue.

Simple buttonhole length adjustment located outside the machine, eliminates the need for tilt back, while the quick stop repair function delivers safety and makes repairs easier.

A halogen work light is included with the S-4000 CAED and LS, to enhance operator safety and product quality.

Special electronic and mechanical safety devices protect the operator and the machine. There is a special power lock out switch that permits the machine to be locked in the off position, so that it cannot be cycled accidentally. There is an emergency off switch. There is a low air pressure detector that will not permit machine operation if air pressure is dangerously low.

There are safety-warning labels on the machine in all areas that require special care. These must not be removed. If they are lost replace them immediately.

You are the most important safety equipment of all. Be sure you understand the proper operation of the machine. Never remove safety mechanisms or labels. We have made every effort to provide the safest possible machine, but without complete knowledge of how this machine operates, and the use of proper care by the operator, this machine can cause serious injury or death. That is why there are safety warnings throughout these instructions that carry one of these messages.

**DANGER!** Possible loss of life.

**WARNING!** Possible serious injury or machine damage.

**NOTICE!** Possible injury or machine damage.

We recommend that service workers from AMF Reece oversee the installation and initial training of your mechanics and operators.

The most effective safety precaution is a well-managed safety program. Be sure those who use this machine are properly trained. Never disable safety equipment.

Always wear safety goggles when operating or servicing the machine.

## A - INTRODUCTION

### 2. SAFETY DEVICE AND LABELS

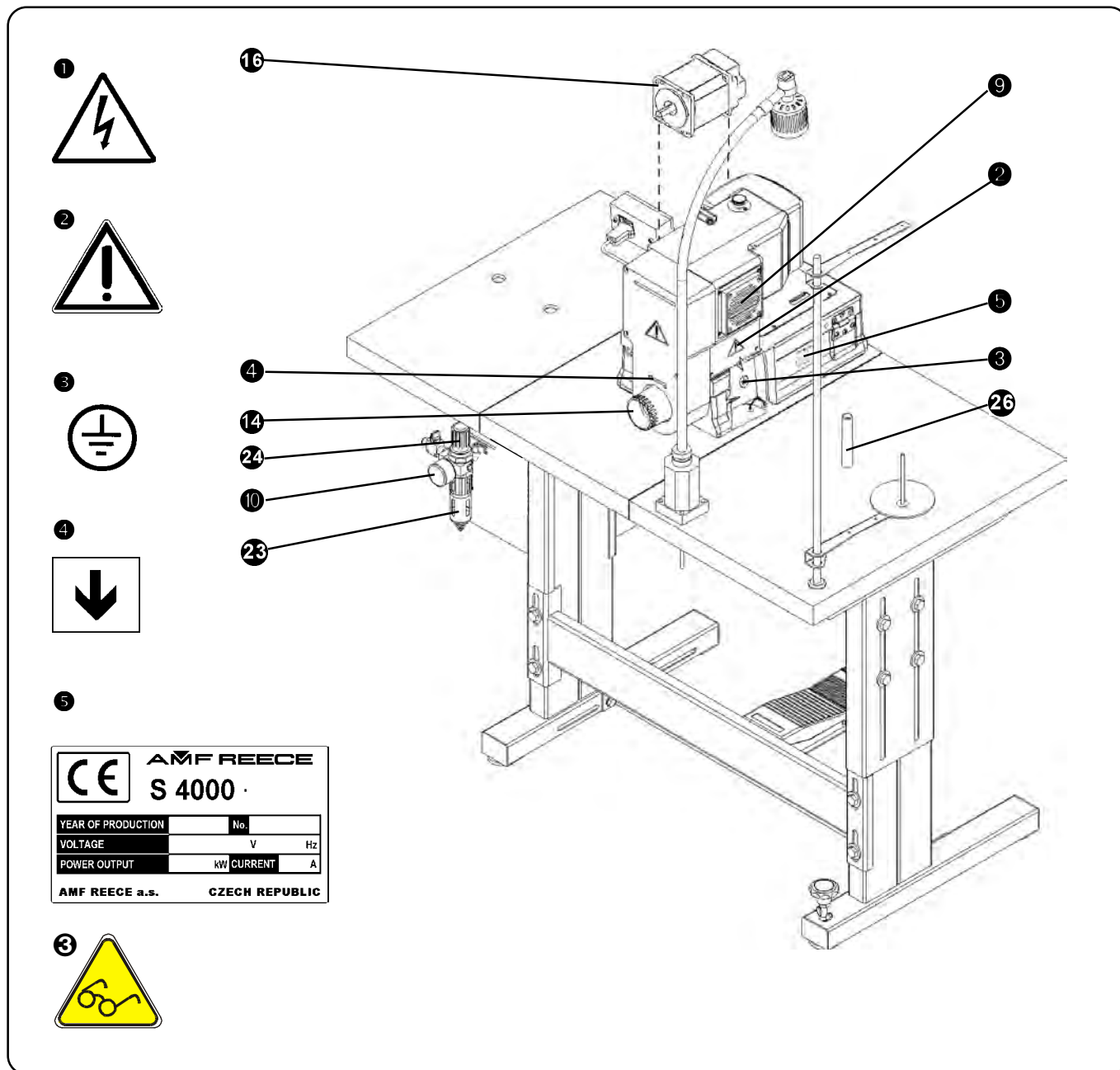

- ❶ Warning
- ❷ Covers removed, possible injury
- ❸ Grounding
- ❹ Rotational direction
- ❺ Standard Label
- ❻ Needle bar cover

- ❼ Eye guard
- ❽ Head cover
- ❾ Fan cover
- ❿ Manometer with pressure sensor
- ⓫ Machine head
- ⓬ Table Frame

## A - INTRODUCTION

### 3. GENERAL MACHINE PARTS DESCRIPTION

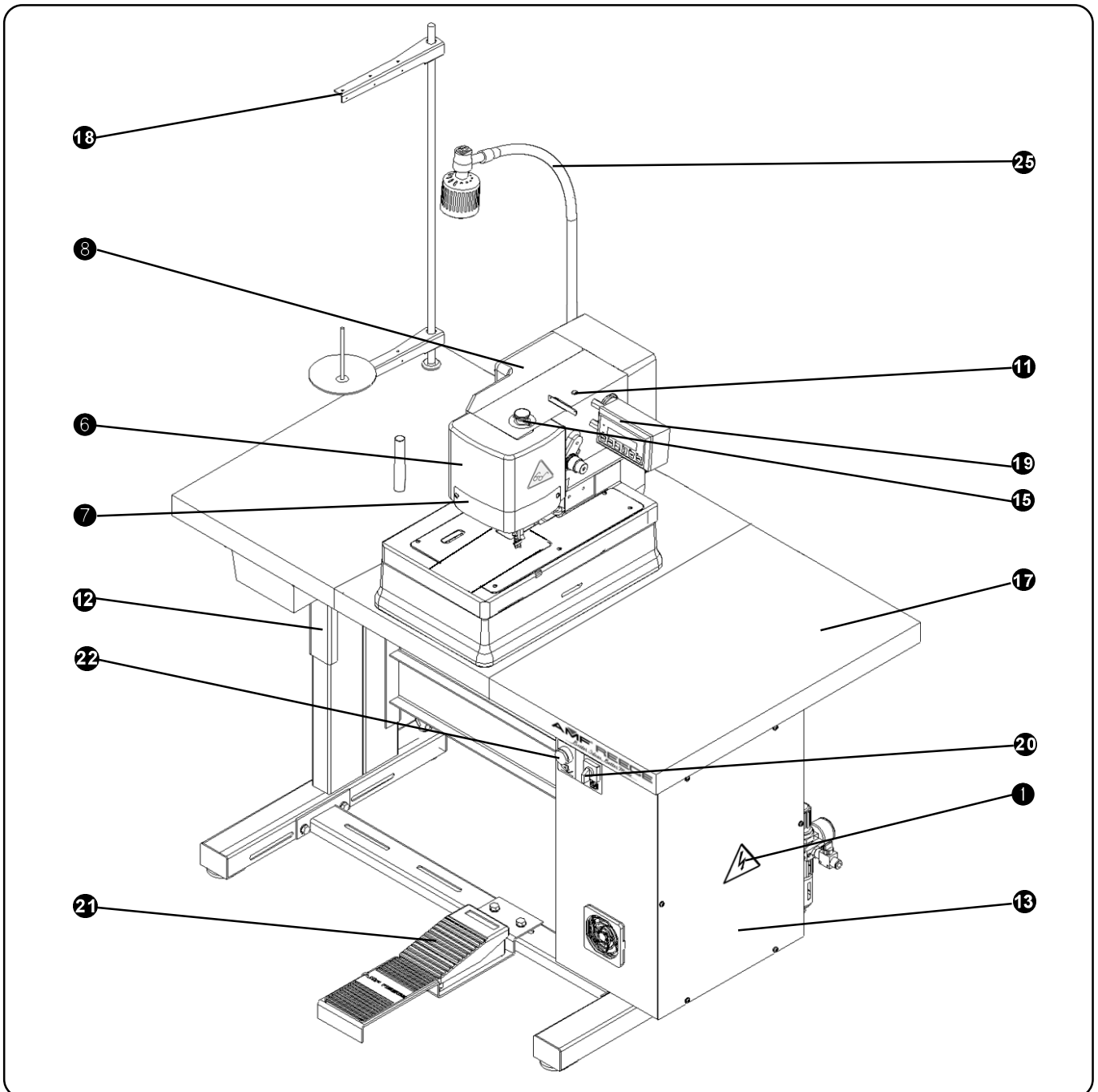

- |                          |   |
|--------------------------|---|
| 13 Control box           | 20 Main switch                                      |
| 14 Hand wheel            | 21 Foot pedal                                       |
| 15 Emergency Stop Button | 22 Clamps Up/Down button                            |
| 16 Motor                 | 23 Air pressure regulator                           |
| 17 Table Top             | 24 Air pressure adjustment knob                     |
| 18 Thread Stand          | 25 Halogen Lamp                                     |
| 19 Control Panel         | 26 Rest Pin   |
|                          | 27 Warning: when opening the cover, mind your eyes! |

## A - INTRODUCTION

---

### 4. SPECIFICATIONS

Machine type	S 4000 CAED
Description	electronical sewing machine for clothing parts stitching with cutting after
Sewing speed	1500-3800 stitches/min
Stitch density	3-14 stitches/cm
Machine clamp foot height	12.7 mm (1/2")
Sewing length	7-50 mm
Knife length	55 mm
Maximum work thickness	to 4 mm (5/32")
Bite size	1,7 - 3,0 mm
Recommended thread	thread size 80, 100, 120 (Tex 40-60)
Needle system	Needle 750 SC 90/14, 70/10 (it is possible to order 80/12)
Lubrication	semi-automatic
Operating Conditions	according to IEC 364-3, IEC 364-5-51 temperature from +5°C to 40°C, relative air humidity from 30 to 80 %
Air pressure	0.55 MPa (80 PSI)
Machine db level	Laeg = 74dB; LWA = 87dB; LpC, peak = 103dB
Machine head dimension	340 mm (height) x 470 (width) x 250 mm (length)
Machine head length	62 kg
Table dimension	700 mm (height) x 600 mm (width) x 1100 mm (length)
Table type	Angle adjustable
Electrical Requirements	1NPE~60Hz 230V/TN-S (according to EN 60204-1) 1NPE~50Hz 230V/TN-S (according to EN 60204-1)
Line Circuit Breaker	10A charakteristic C (according to EN 60947-2) 16A charakteristic B (according to EN 60947-2)

## A - INTRODUCTION

### 5. INSTRUCTIONS FOR OPERATOR SAFETY AND MAINTENANCE

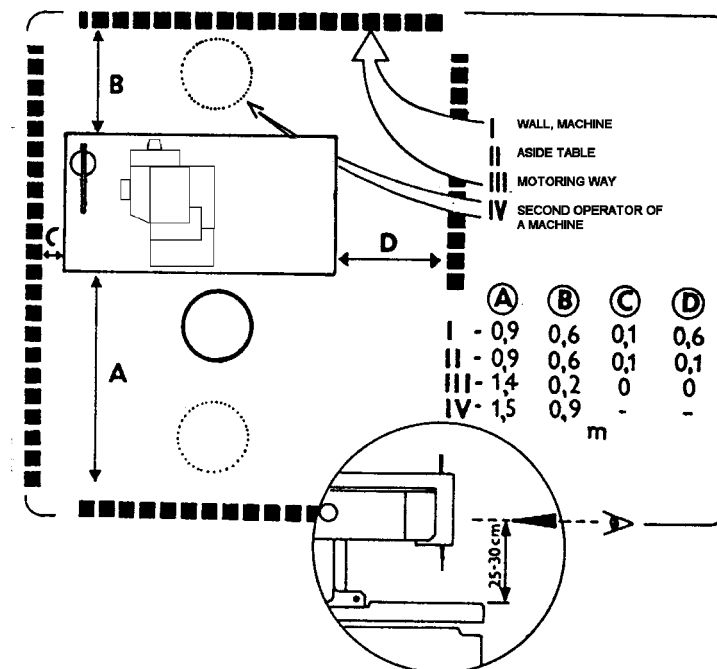

When installing the machine we recommend the minimum clearances noted above around the machine. Read all of the instructions that follow. **DO NOT PUT THE MACHINE INTO OPERATION UNTIL YOU ARE COMPLETELY FAMILIAR WITH ALL INSTALLATION AND OPERATING INSTRUCTIONS.**

**DANGER!**

- Before connecting the machine to the power supply, be positive that all safety covers are correctly installed.
- Always engage the power lockout switch, or disconnect the main power supply, before removing any safety covers.

**WARNING!**

- Locate the Emergency Stop button. Be sure you know how to use it.
- Be sure that you have a reliable and uniform power supply.
- Be sure that all electrical supply lines are in good condition and have no signs of damage to avoid electrical shock.
- If any covers become damaged, they must be repaired or replaced immediately.
- Do not touch moving parts of the machine while it is operating.
- Keep clear of the needle.
- Always switch off the main power before changing the needle.
- Before cleaning the machine or performing service to the machine, engage the power lock out switch or disconnect the main power supply.
- When the machine is not in use engage the power lock out switch or disconnect the main power supply.
- When this machine is used incorrectly, or is incorrectly maintained, it can be dangerous. Everyone who uses this machine, or maintains this machine, must be completely familiar with this manual.

## A - INTRODUCTION

### CAUTION!

- Perform all regular service as described in this manual.
- If there is any problem with the power supply, turn off the main power switch.
- Do not remove, paint over, damage or in any way change safety labels. If a safety label cannot be easily read, replace it.
- Long hair and loose clothing may be dangerous near any machinery. Always contain long hair and avoid loose clothing, so that it cannot be caught by machinery and cause injury.
- Never use this machine while under the influence of drugs or alcohol.
- If anything seems to be operating incorrectly in the machine call for maintenance assistance immediately.
- Be sure that there is adequate light for safe operation. A normal minimum light level is 750 lux.

### 6. SPECIAL ACCESSORIES

- machine device, which is not included in the standard equipment of the machine and can be ordered by the customer

#### Voltage guard - relay HRN 35 06.2400.0.004

The machine operation is ensured when the power supply is in range AC 230V  $\pm 10\%$  (EN 60204-1). It is possible to equip the machine with the relay HRN-35 in case of larger fluctuation of power supply.

It prevents the machine from damage and in case of large decrease of power supply, the operator is informed by error message.

If the power supply range is exceeded - max 255V and min 185V the voltage guard - relay HRN-35 which ensures that machine does not start. After the power supply is in required range, it is possible to start the machine.

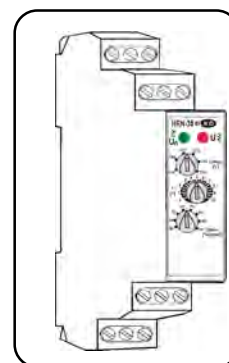

The manufacturer recommends to use the external stabilizer in case of large fluctuation of power supply.

#### Needles 750 SC 80/12, 90/14

- the manufacturer recommends to use these needles when sewing thin material
- part numbers 02.0750.2.100 (80/12), 02.0750.2.110 (90/14)

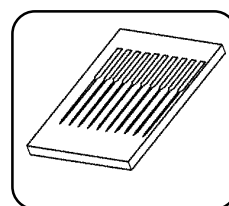

## A - INTRODUCTION

### Connector Ø 8 ①

- order it if the connecting tube has the inner diameter 8 mm. The connector Ø 10 is supplied with the machine.
- part number is 12.0008.3.607

### Reduction ②

- place an order in case you use connections with inch threads (order number 12.0008.3.081)

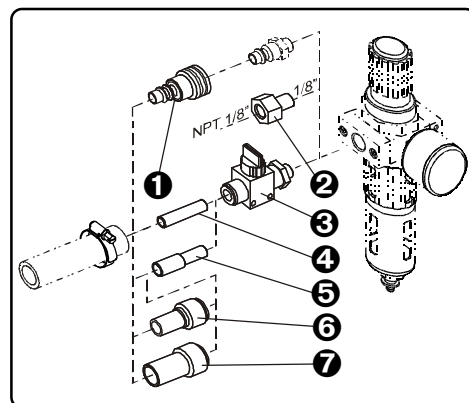

### Hand valve ③

- to dissipate any air from the machine, order it (air circuit is bled). It is necessary to order the connectors (see below) to the hand valve for connection to the air tubes.
- part number 12.0008.3.463

### Connectors

④	12.0008.3.464	Ø 8	for connection to the tube with inner Ø 8 mm
⑤	12.0008.3.466	Ø 10	for connection to the tube with inner Ø 10 mm
⑥	12.0008.3.467	Ø 12	for connection to the tube with inner Ø 12 mm*
⑦	12.0008.3.465	Ø 16	for connection to the tube with inner Ø 16 mm*

\* To connect the tube with inner Ø 12 and Ø 16, it is also necessary to order Ø 10.

### Thread Draw - Off Kit 03.5524.0.004

- order this device if you would like to use the machine for both, sewing and trimming.

without  
trimming

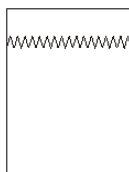

with trimming

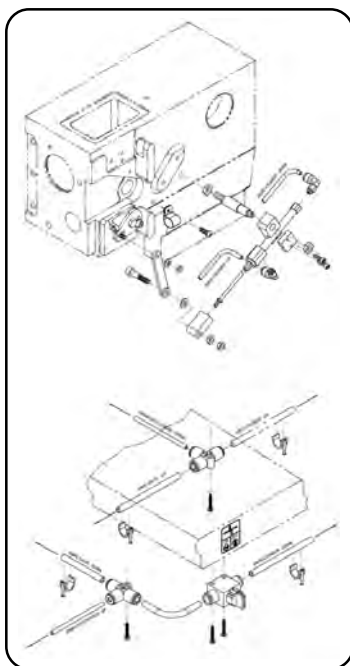

### Thread Blow - Off Kit 03.5524.0.023

- the device enables thread tail at the needle to be caught above the clamping feet

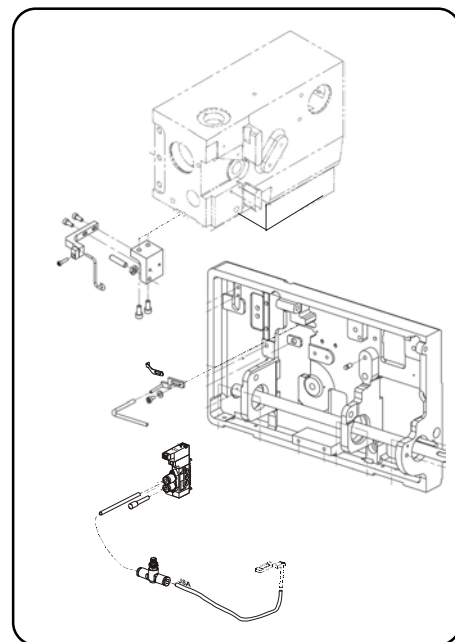

## B - MACHINE ASSEMBLY

### 1. CONTENT OF THE SHIPPING BOX

1. The shipment contains one box.
2. There is a carton with accessories, service manual with parts section and thread stand ❶ in the box.
3. During unpacking the shipment, follow the labels which are on a cover.

**CAUTION:** If the machine or crate was damaged in shipment inform the freight company immediately. Check the contents of the crate immediately and report any damage or missing items to the manufacturer immediately, late reports will not be considered!

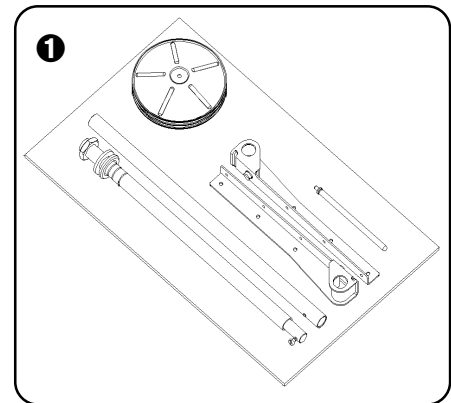

### 2. ACCESSORIES

A package of accessories is supplied with the machine, please refer to page 3-48 for detailed descriptions. The height of the working area is normally set in range 830 - 850 mm from the manufacturer. When using this height of the working area, recommended height of the operator seat is in range 430 - 460 mm. The height of the table can be set in range 670 - 880 mm by screws ❸.

\* It is possible to tilt the operator's head up to 5°.

Remove the shipping strap ❷ after unpacking the machine, the use of this strap is recommended anytime the machine is transported (This is valid for all types of tables - parallel, crosswise).

#### STANDARD ACCESSORIES

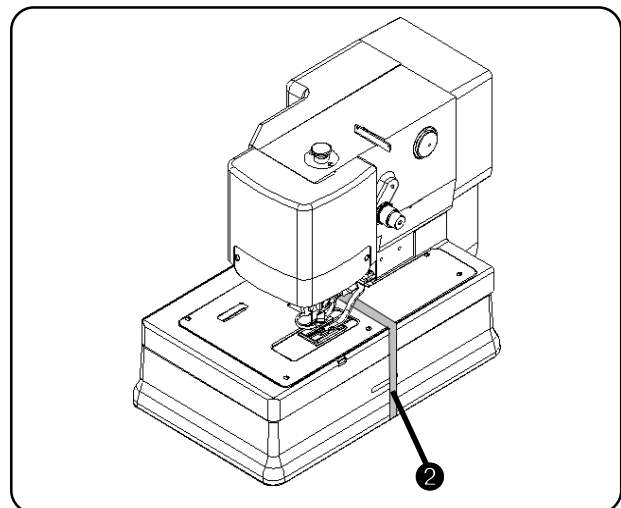
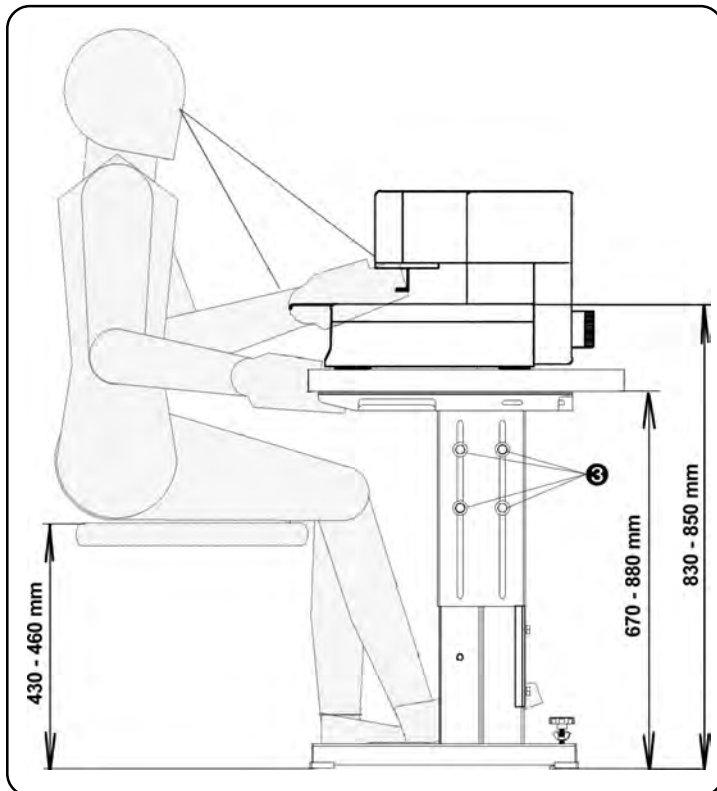
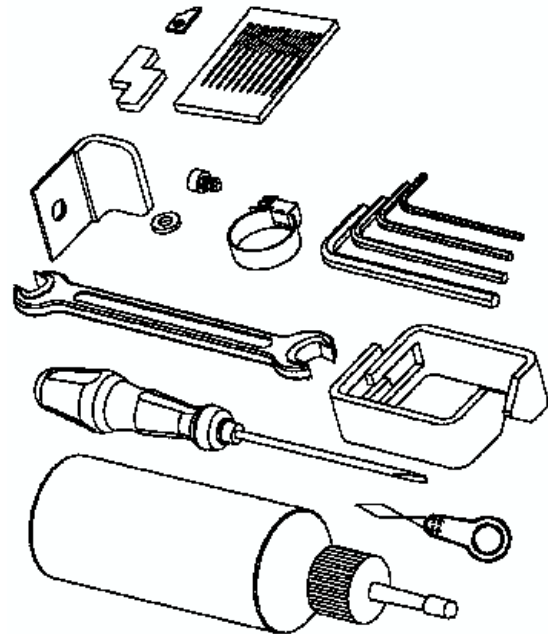

## B - MACHINE ASSEMBLY

### 3. POWER AND AIR CONNECTION

- The machine is equipped with a quick coupler **4** required with connector **5** for inner Ø of the tube 10. The connector for inner Ø of the tube 8 is not supplied with the machine, a customer has to order it. The manufacturer recommends to use connector **6** for customers who requires to connect the tube with connector NPT.

If a customer needs to use a shut off valve **1**, which allows fast releasing of the air from the circuit, he must order it.

A variety of connectors **2** can be used separately or in combination to adapt to the available input supply hose. It depends on type of the tube which is used by a customer. These connectors are not included in the accessories. A tubing clamp **3** is provided.

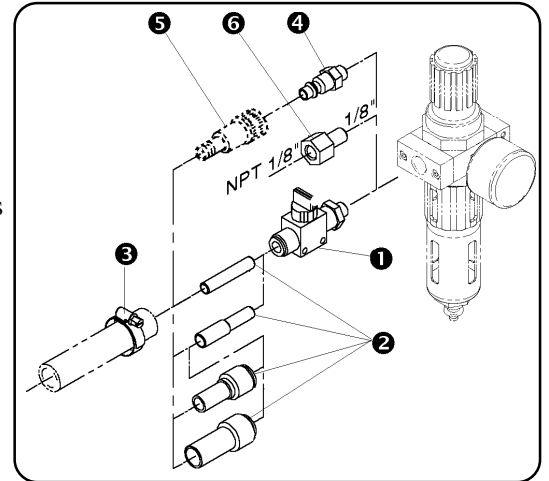

**NOTE:** Parts **1**, **2**, **5**, **6** are included in Extra Parts - see 3-48.

- After air connection check the set air pressure on the dial of the regulator. It should be in range 0.5 - 0.6 MPa. The green pointer **7** indicates the lowest working air pressure 0.5 MPa, which is set from the manufacturer on the regulator **8**. If the air pressure is lower than 0.5 MPa after connecting the machine to the power supply, „Low Pressure“ message appears on the control panel display. To adjust the working pressure, loosen the regulator cap lock **10** and turn the regulator cap clockwise to increase the pressure. Push the regulator cap **10** down. The LED **11** is for setting the minimal operation air pressure.
- Power supply must be 230 volts. Receptacle plug must meet requirements of IEC standard 364-4-41, its circuit breaker must be minimal 10A with characteristic C according to the EN 60947-2 (or 16A with characteristic B). No other devices must not be connected to the circuit breaker of the socket. The hand wheel **12** must turn counter clockwise.

**The machine is equipped with a filters which contain capacitors which generate an high frequency leakage current. In order to prevent nuisance tripping, residual current protection device must be protected against these high frequency currents: this is the case for industrial residual current device (example „S“ type).**

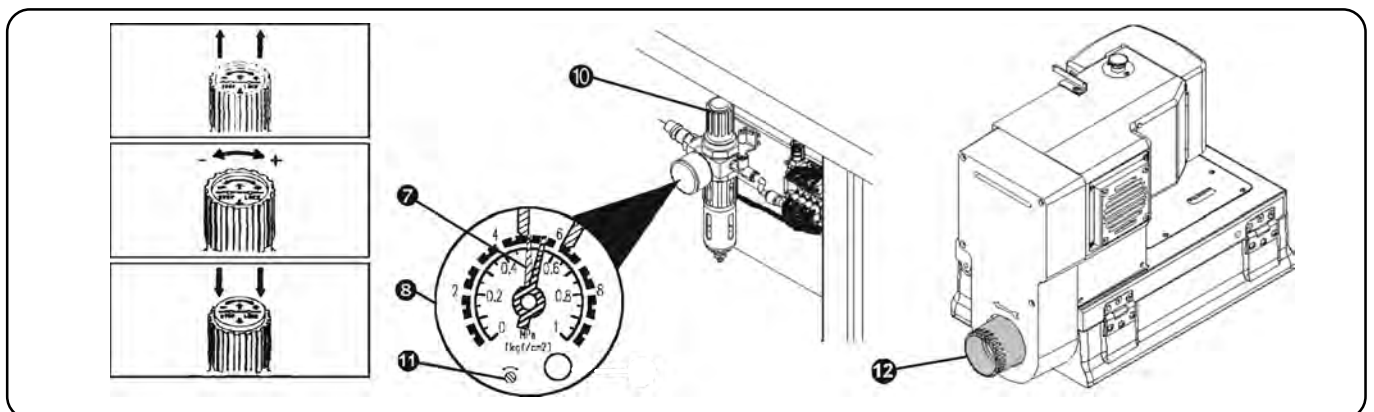

## B - MACHINE ASSEMBLY

### 4. HEAD PNEUMATIC

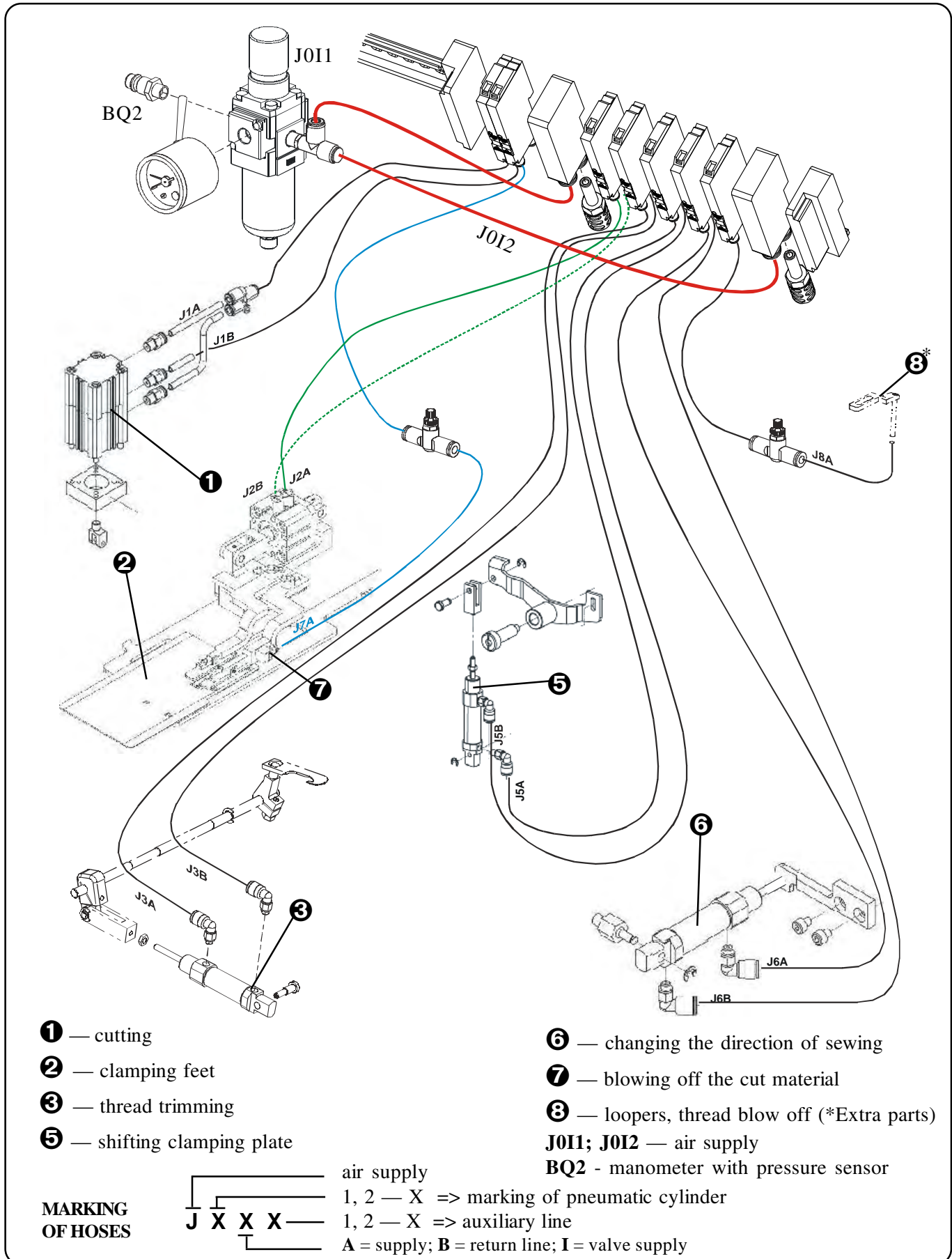

## B - MACHINE ASSEMBLY

### 5. INSTALLATION OF THREAD HOLDER

1. Put the thread holder together as per the drawing.
2. Position of the ring **1** enables assembly of the complete holder onto tables with different thickness of the tabletop. The end of the rod with threads **6** shall not overtop the nut more than 1 mm.
3. Once the ring **1** is positioned, insert the mat **2** with the groove towards the ring; place the rod into the opening in the tabletop **3** (on the right at the back). Tighten the nut **5** with the mat **4** underneath.

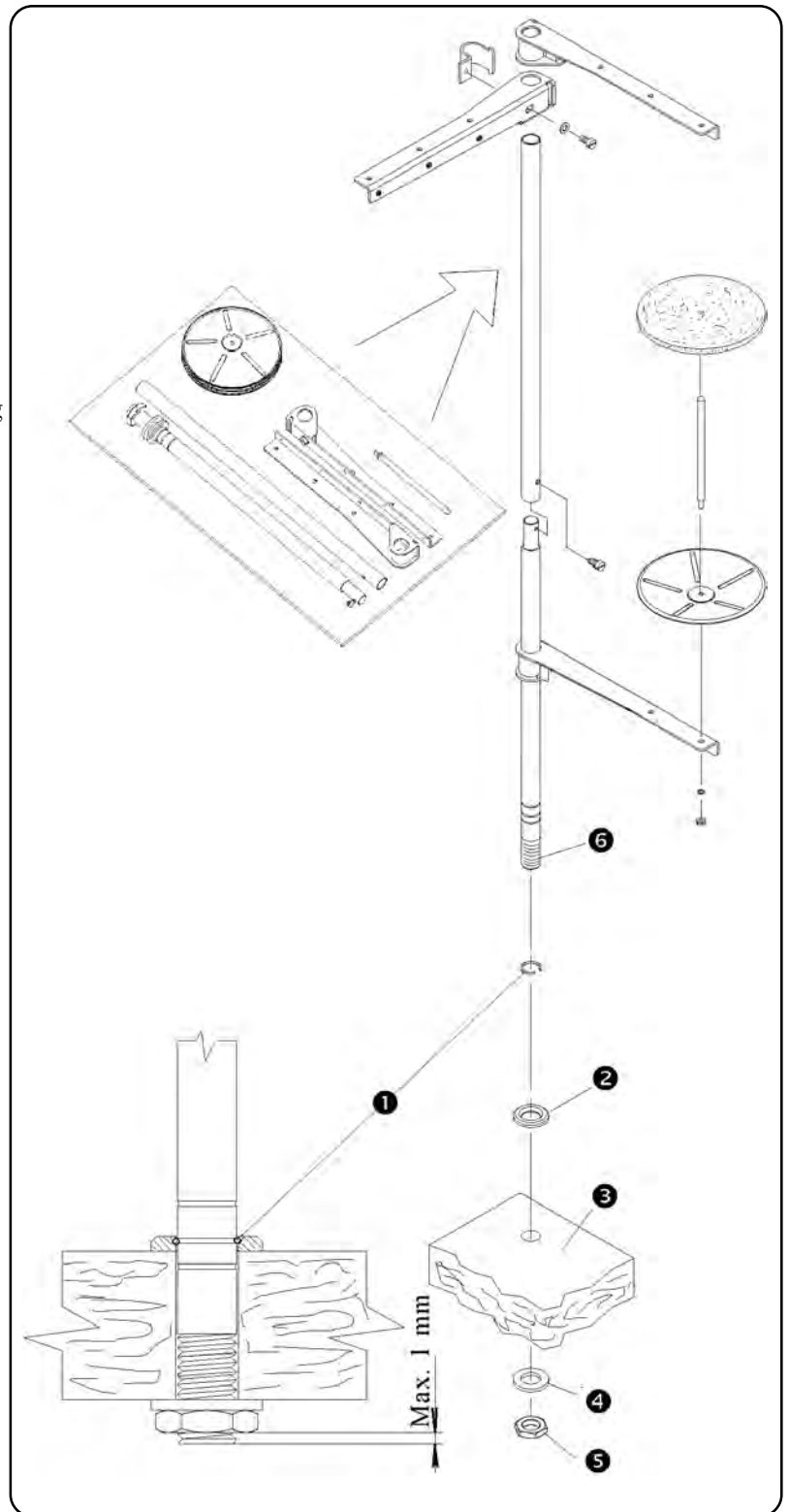

## C - PROPER APPLICATION

### 1. POWER UP/HOME POSITION

1. Turn the main power switch on **1** by turning clockwise to the **I** position.
2. The display is illuminated for a moment and the screen shows the model number.

<b>AMF Reece</b> <b>S 4 0 0 0 CAED</b>
---

3. The machine is ready for operation when the Ready message appears on the display and the green LED lights.

Ready <span style="float: right;">262</span>
---

The machine must be in the home position before starting to sew (to be certain, press the foot treadle and sew one buttonhole).

4. It is possible to install the power voltage control (Voltage monitoring relay HRN 35) into the machine control system. This power voltage control cautions a machine operator if the supply voltage is not in the required range (185V - 255V) and the machine could be damaged - see section **E19**.

**Note:** The power voltage guard is installed in the machine only if a customer has ordered it with the machine.

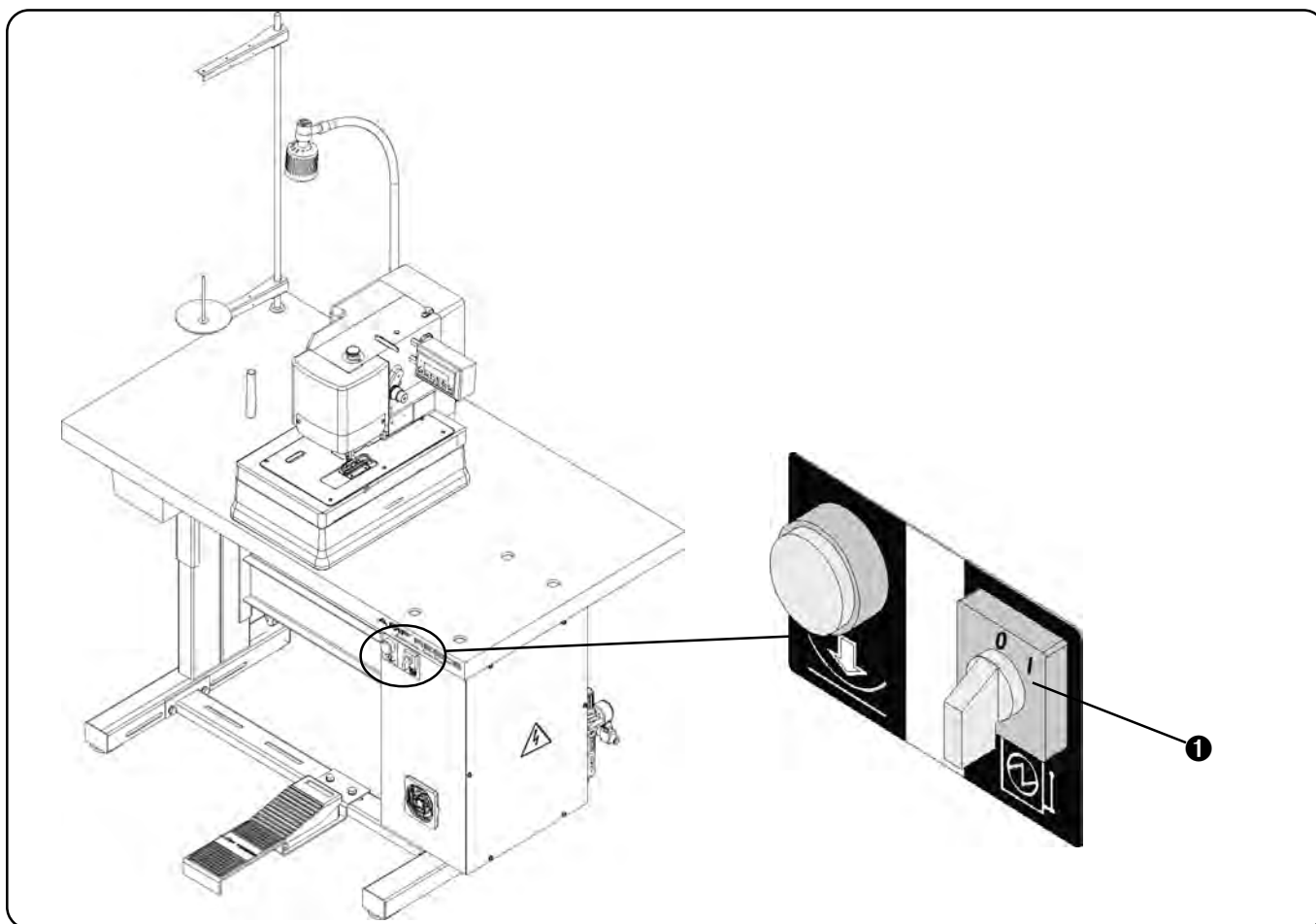

## C - PROPER APPLICATION

### 2. NEEDLE INSTALLATION

**WARNING!** Before doing this adjustment, switch the machine off and let the remaining compressed air from the machine out.

For thin fabrics the machine uses needles order number 02.0750.2.109 (750 SC 70/10— Groz-Beckert) as standard and for thicker fabric needles order number 02.0750.2.110 (750SC 90/14— Groz-Beckert) – see accessories. It is possible to use needles order number 02.0750.2.100 (750 SC 80/12 - Groz-Beckert) for thin fabric – these needles are not in a standard accessory kit.

1. Using the screwdriver push the latch **1** and open the needle bar cover **2**.

**Note:** The accessories contain the lever **5** (part number 22.0213.0.000) and screw (part number 08.6000.4.005) with washer (08.6850.4.000) **6**, which is possible to fit to the latch. It allows opening of the cover without using the tool.

2. Loosen the screw **3** and remove the needle.
3. Insert the new needle so that the long thread groove **4** is in the rear and the spot for the clamping screw **3** is in line. Do not install a bent or broken needle. Roll the needle on a flat surface to check for straightness.
4. Tighten the screw **3** well.

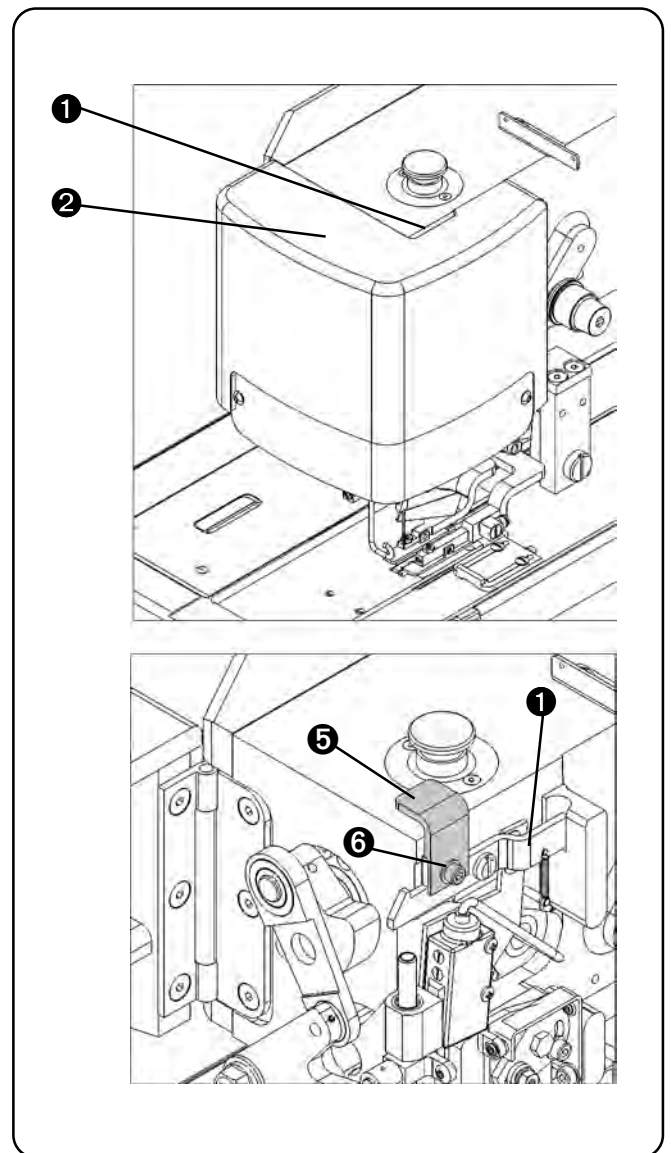
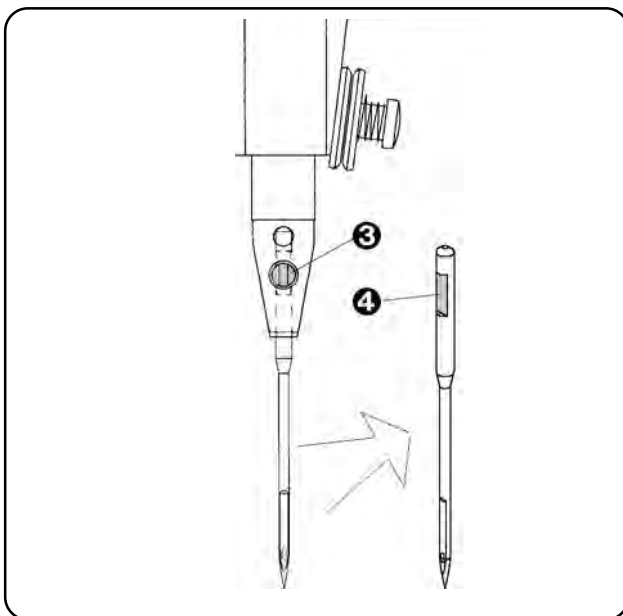

## C - PROPER APPLICATION

### 3. THREADING

**WARNING!** Switch the main machine power off to prevent accidental starting of the machine. Disconnect the air supply and dissipate any stored energy.

When threading, see the pictures below. Change the thread tension by nut ❶ according to the sewing conditions. To increase the thread draw off (for example sewing on the thin fabrics) there is an arm ❷ installed on the thread draw off lever.

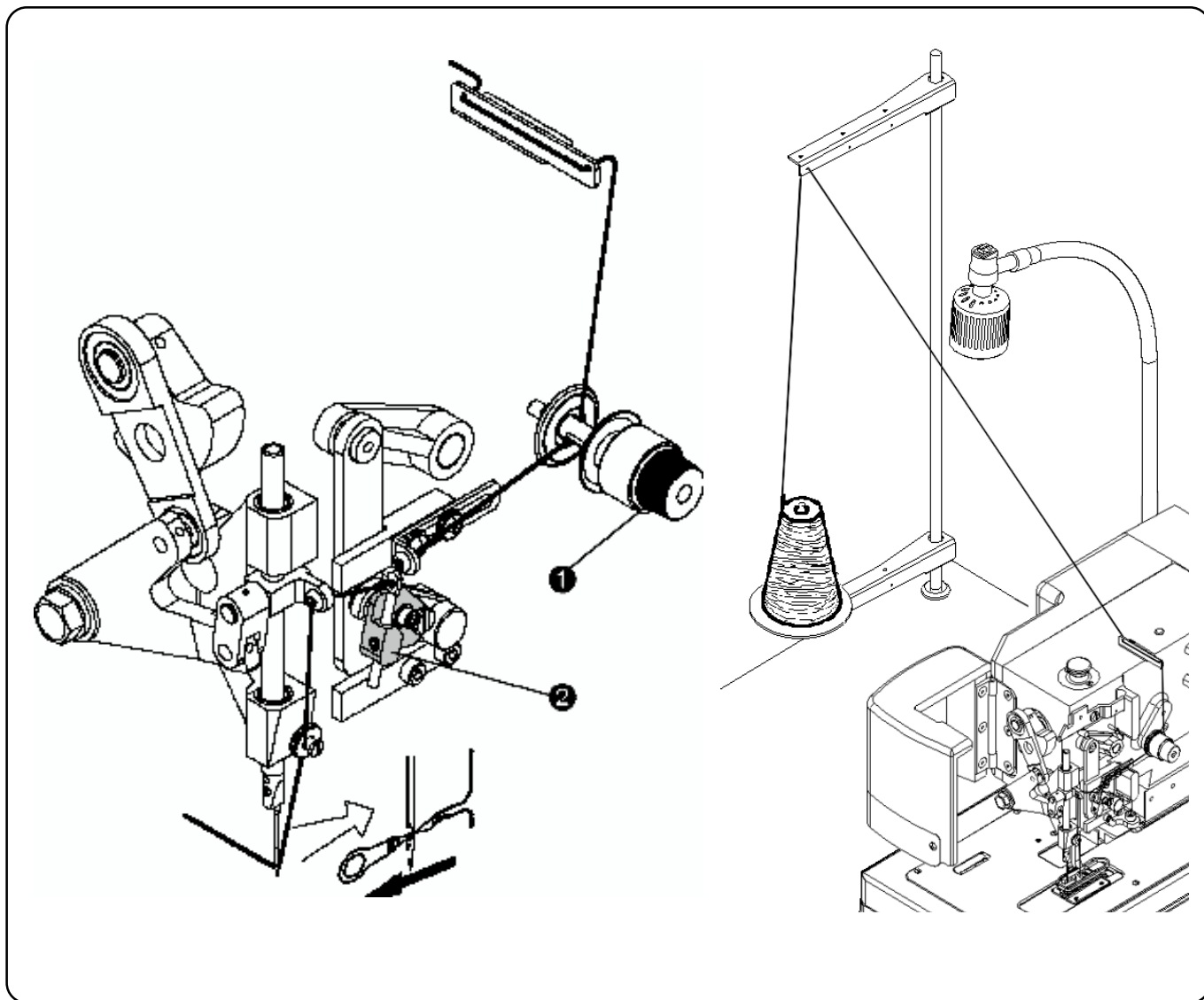

*The appearance and quality of the sewing may be affected by one or more of the following:*

- clamping of the material
- thread tension
- type of thread (size etc.)
- sewn material (thickness, density)

## D - MACHINE CONTROLS

### 1. PROGRESS OF SEWING

1. Bring the machine to the home position according to the section C1.
2. Be certain that the machine is threaded correctly according to the section C3 and insert the work under the clamp feet.
3. When the foot pedal **3** is pressed to the first position, the work is clamped by the clamp feet. (Releasing the foot pedal will rise the clamp feet).

*Note:* It is possible to set in the program the machine start on first pedal position.

4. When the foot pedal is pressed to its second position, the sewing is started. After finishing the sewing and trimming the thread, the machine returns to the home position and the clamp feet rise.
5. When the clamp feet are up, it is possible to move the sewn work for next sewing.
6. Machine can be stopped in any place of the cycle by pressing the Emergency Stop button **4** which is placed on the machine head. After releasing the Emergency Stop button, pressing the  button and pressing the foot pedal, the machine finishes the sewing.
7. If the foot pedal **3** is pressed before finishing the sewing, the clamp feet will not rise and the machine will sew four cycles instead of two - this is possible to set in program.
8. When the work is done, switch the machine off by the **5** button.

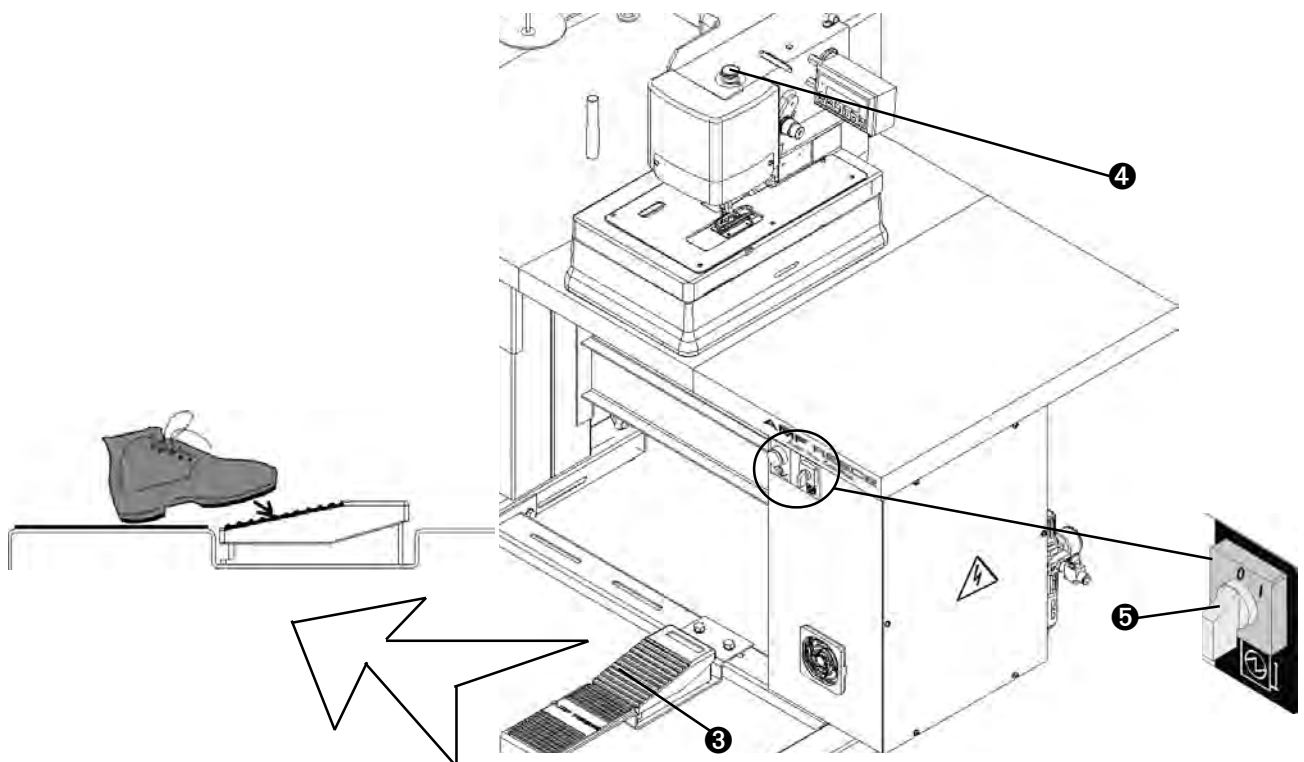

## D - MACHINE CONTROLS

### 2. OPERATOR CONTROL PANEL PUSH BUTTONS AND SWITCHES

Indicator signaling that the Emergency stop button is activated.

Indicator signaling that the machine is ready to start sewing.

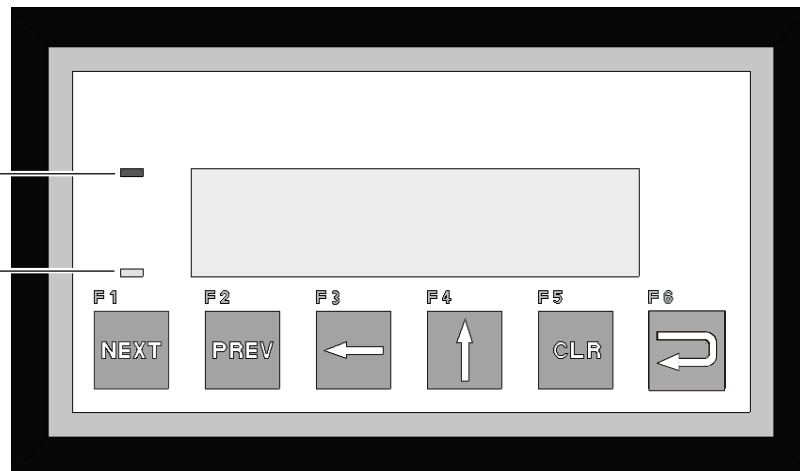

F1



“Next” button – move onto the next screen

F2



“Previous” button – move back onto the previous screen

F3



Button to set up parameter values (in programmable menu)

F4



Quick access into parameters used most often  
Button to set up parameter values (in programmable menu)

F5



“Clear” button – return onto the main screen, return onto the screen viewed or changed last

F6



“Enter” button (in programmable menu)



“Emergency stop” button



“Clamp feet” button

## D - MACHINE CONTROLS

### 3. CONTROL PANEL INFORMATION (MAIN SCREEN)

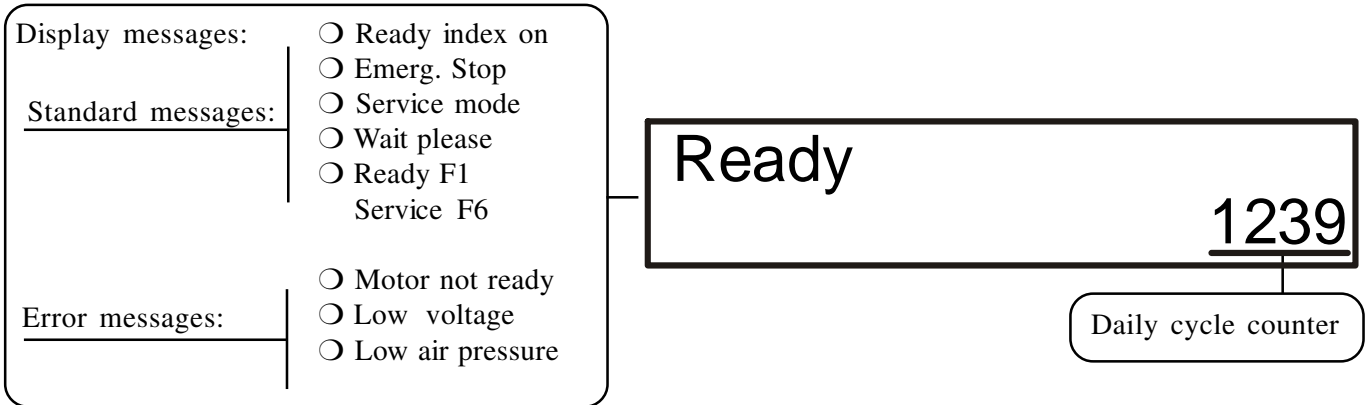

**ATTENTION!** When doing any kind of adjustment, keep your hands off the needle area. The basic machine design is equipped with a pedal control; therefore never place your foot onto the foot pedal.

Error messages on the display are mentioned in *Troubleshooting* section.

### 4. THE PROGRAMMING MENU

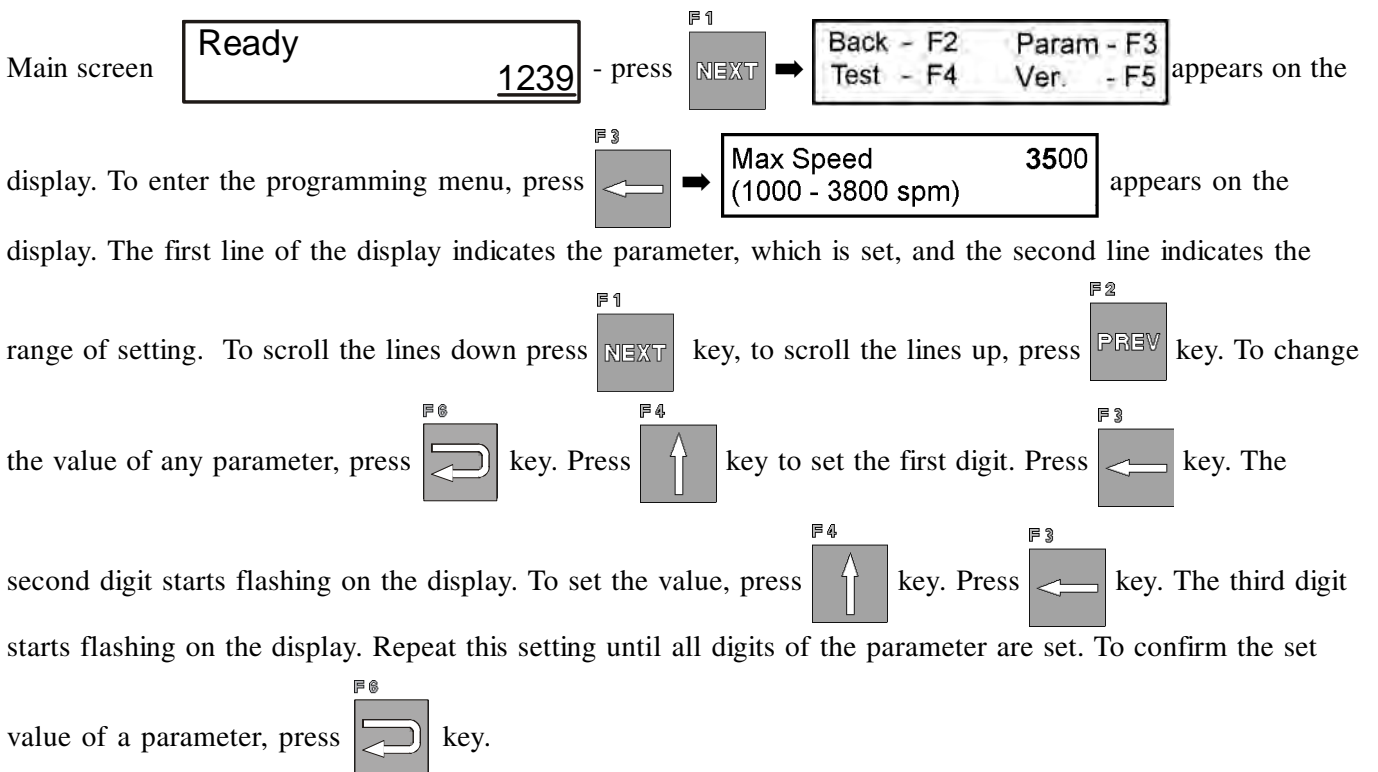

## D - MACHINE CONTROLS

**Example:** To change the sewing speed from **2000** to **3450**

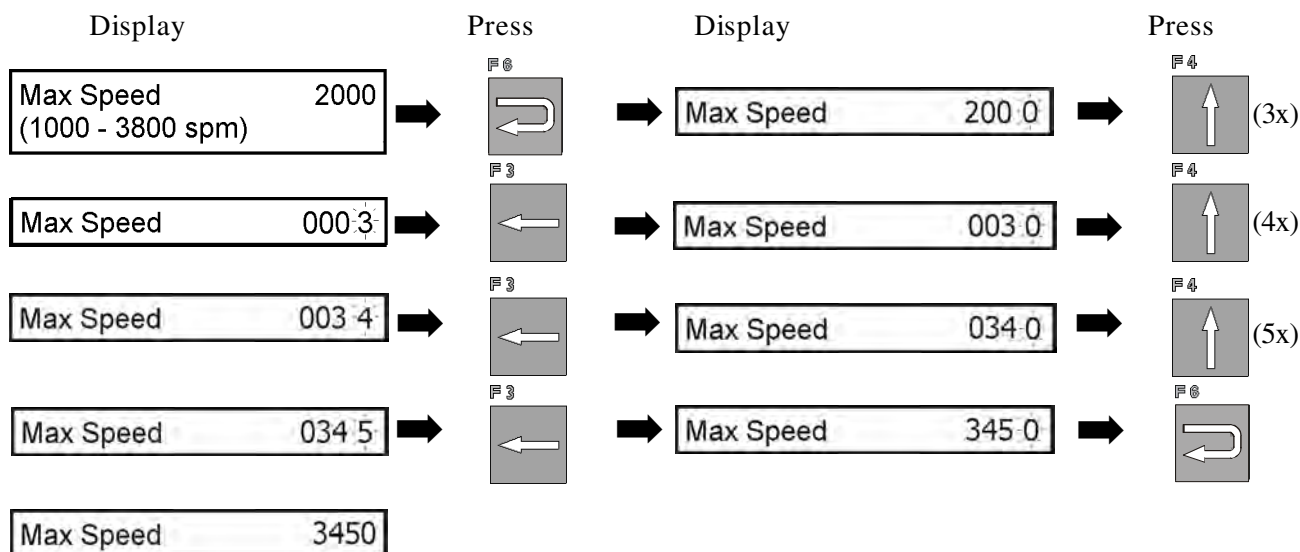

- | Display                           |  |
|-----------------------------------|--|
| 1. Max Speed (1000-3800 rpm) 3500 | - maximal speed. Range <b>1000-3800</b> spm.   |
| 2. Slow stitch (0-3) 0            | - selecting the number of stitches in slow start. Range <b>0-3</b> .                                       |
| 3. Slow speed (500-1000 spm) 1000 | - setting the slow start speed at the beginning of the sewing cycle. Range <b>500-1000</b> rpm.            |
| 4. Ndl up pos (0-600) 320         | - correction of the needle bar upper position. Range <b>0 - 600</b> imp.                                   |
| 5. Knife delay (60-135 ms) 120    | - setting the knife/draw-off delay. It is possible to set it in range <b>60-135</b> ms.                    |
| 6. Knife time (30-200 ms) 100     | - setting the timing of the knife/draw-off activation. It is possible to set it in range <b>30-200</b> ms. |
| 7. Trim delay (145-200 ms) 150    | - setting the trim delay. It is possible to set it in range <b>145 - 200</b> ms.                           |
| 8. Trim time (30-60 ms) 50        | - setting the timing of trim activation. It is possible to set in range <b>30 - 60</b> ms.                 |
| 9. Clamp Delay (0-100 ms) 50      | - setting the clamp opening delay at the end of cycle.   |

It is possible to set in range **0-100** ms.

## D - MACHINE CONTROLS

- Display
- |     |  |   |   |
|-----|--|---|---|
| 10. | Cycle delay<br>(500-2500 ms)      500              | - | setting the delay between the sewing cycles. Cycling parameter must be activated. It is possible to set it in range <b>500-2500</b> ms.   |
| 11. | Cycling<br>(yes/no)              no                | - | activation of the machine cycling. It is possible to set <b>Yes / No</b> .  |
| 12. | Pedal<br>(1step/2steps)      2steps                | - | setting the foot pedal position for sewing start. Possible setting <b>1 step / 2 steps</b> .  |
| 13. | Double sew<br>(1, 2 = 1 or 2, 3 = 2)      1        | - | setting the number of cycle repeat. It is possible to set <b>1, 2 = 1 or 2, 3 = 2 = 1 or 2</b> . When "2" is set, 2 cycle repeat are selected by holding the pedal while sewing.                              |
| 14. | Lcount              1239<br>Count Rst          No  | - | total cycles counter.   |
| 15. | Lcount              1239<br>Count Rst          Yes | - | daily counter restart  = set "yes" to restart.   |
| 16. | Mater. blow          40<br>(1-100 x 10ms)          | - | setting the air blow timing of cut-off material. Range 10-1000ms.   |
| 17. | Direction              0<br>(0-30 stitches)        | - | Setting of number of stitches sewn over the fabric/garment edge. Range 0-30 stitches. This range is necessary to adjust according to the mechanically set sewing density and electronically set sewing speed. |
| 18. | Optical sens          Yes<br>(Yes/No)              | - | optical sensor function activation (Yes/No).  |
| 19. | Thread blow          30<br>(1-100 x 10ms)          | - | setting the thread blow timing. (If this device is installed on the machine.) Range 10-1000ms.  |
| 20. | Shift time              4<br>(3-9 x 100ms)         | - | setting the clamping plate shift time. Range 300-900ms.   |

To return to the main screen, press  key Ready              1239.

### 4.1. Quick access into parameters used most often



Max Speed          3500 (1000-3800 spm)	-	Maximal sewing speed. Can be set up within the range of 1000 –3800 stitches per minute
--	---	--

Double sew          1 (1, 2=1 or 2, 3=2)	-	Number of rows to be sewn. Possible to set <b>1, 2 = 1 or 2, 3 = 2</b> .
---	---	--



## D - MACHINE CONTROLS

Display

Press F3 to Rst  
Counter: 4538

- Counter of total number of cycles



**Direction** 0  
(0-10 stitches)

- Setting up number of stitches sewn over the edge of fabric / workpiece.

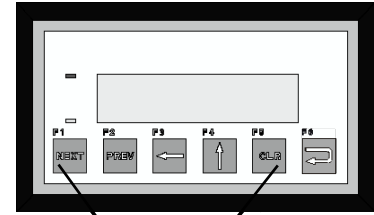

Return onto the main screen

### 5. TESTS

**WARNING! TESTS CAN BE CARRIED OUT BY QUALIFIED SERVICE ENGINEERS ONLY!**  
**CAUTION! BEFORE STARTING THE TESTS REMOVE CUTTING KNIFE AND NEEDLE.**

With the main screen on the display, press . 

Back - F2	Param - F3
Test - F4	Ver. - F5

 appears on the display. In order to

enter TEST menu, press . 

Input tests	Off
Low air pres	Off

 appears on the display. You can browse through the

menu down by pressing the button or up pressing the button .

#### INPUT (TESTS)

Display

1. 

Input tests	Off
Low air press	Off

- 

Input tests	On
Low air pres	On

 this appears on the display in case the air pressure is lower than 0,5 MPa. This parameter checks the switch BQ2.

2. 

Home sensor	Off
Voltage Rly	Off

- The end position sensor. Activate the sensor with a metal item.

Home sensor	On
Voltage Rly	Off

 appears on the display.

This parameter checks the switch BQ1.

3. 

Home sensor	Off
Voltage Rly	Off

- This only input signify if the voltage relay is installed on the machine. If

the power voltage drops below 185V, 

Home sensor	Off
Voltage Rly	On

 appears on the display. This parameter checks the relay VC 1 min.

4. 

Pedal 1 step	Off
Pedal 2 step	Off

- Once the foot pedal is pressed into the first position,

Pedal 1 step	On
Pedal 2 step	Off

 appears on the display.

This parameter checks the switch SB4.

5. 

Pedal 1 step	Off
Pedal 2 step	Off



























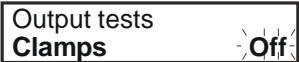



- After pressing the foot pedal into the second position,

Pedal 1 step	Off
Pedal 2 step	On

 appears on the display.

This parameter checks the switch SB5.

## D - MACHINE CONTROLS

6.  - After pressing  button,  appears on the display. After releasing the button  appears on the display. This parameter checks the switch SA1.
7.  - By pressing the clamps  button  appears on the display and clamps close. By pressing this button once more, the clamps are lifted. This parameter checks the switch SB3.
8.  - If  appears on the display, go to the section "Troubleshooting".
9.  - Correction of the sensor position. If the fabric is inserted, 
-  key on the last inputs test screen  appears on display. By pressing  key you choose the row you need to change. The changed output is signalized by blinking. Press  to get to the following screen. Press  to go back in tests. Press  key to get back to the main screen.
- Display
10.  - To activate clamps, press  key → , confirm  →  clamps close. To lift the clamps, press  key → , confirm  →  and clamps are lifted. This parameter tests the YV2 value.
11.  - To activate the cutting lever and draw off, press  → , confirm  →  Cutting lever moves down. This parameter tests the YV1 valve.

## D - MACHINE CONTROL

12. 

Knife Trim	Off
Off	Off

 - To activate thread trimming, press key → 

Knife Trim	Off
Off	Off

, confirm → 

Knife Trim	Off
Off	On

. This parameter tests the YV3 valve.
13. 

Shift	Off
Off	Off

 - To activate clamping plate shift, press key → 

Shift	On
Off	On

, confirm → 

Shift	On
On	On

 and the clamp plate is shifted. This parameter tests the valve YV5 valve.
14. 

Direction Mater. Blow	Off
Off	Off

 - To activate shifter press the key → 

Direction Mater. Blow	On
Off	Off

, confirm → 

Direction Mater. Blow	On
Off	On

 and the cylinder for shifter is moved. This parameter tests the YV6 valve.
15. 

Direction Mater. Blow	On
Off	Off

 - To activate this press the key → 

Direction Mater. Blow	On
On	On

, confirm → 

Direction Mater. Blow	On
On	On

. The clamping foot starts blowing air. This parameter tests the YV7.
16. 

Thread Blow	Off
Off	Off

 - To activate the thread blow off press the key → 

Thread Blow	On
Off	On

. Confirm → 

Thread Blow	On
On	On

, the air starts blowing. This parameter tests the YV8 valve (if this valve is assembled).

## 6. PROGRAM VERSION



## D - MACHINE CONTROL

---

### 7. PARAMETER CHECKLIST

PARAMETER	RANGE	SETTING
MAX SPEED	1000-3800 rpm	3500
SLOW STITCH	0-3	0
SLOW SPEED	500-1000 rpm	1000
NDL UP POS	0-600 imp	320
KNIFE DELAY	60-150 ms	120
KNIFE TIME	30-200 ms	100
TRIM DELAY	0-200 ms	150
TRIM TIME	30-60 ms	50
CLAMP DELAY	0-100 ms	50
CYCLE DLY	500-2500 ms	500
CYCLING	yes/no	No
PEDAL	1 step / 2 steps	2 steps
DOUBLE SEW	1, 2 =1 or 2, 3 =2	1
MATER. BLOW	10-1000 ms	40
DIRECTION	0-10 stitches	0
OPTICAL SENS	yes/no	yes
THREAD BLOW	10-1000 ms	30
SHIFT TIME	300-900 ms	400

## E - MACHINE ADJUSTMENTS

### 1. MACHINE HOME POSITION

1. Needle bar is in the upper position. When making the first stitch, the needle ❶ must go into the right side throatplate groove ❷. Mark ❸ on the hand wheel must meet mark ❸ on the pulley cover.

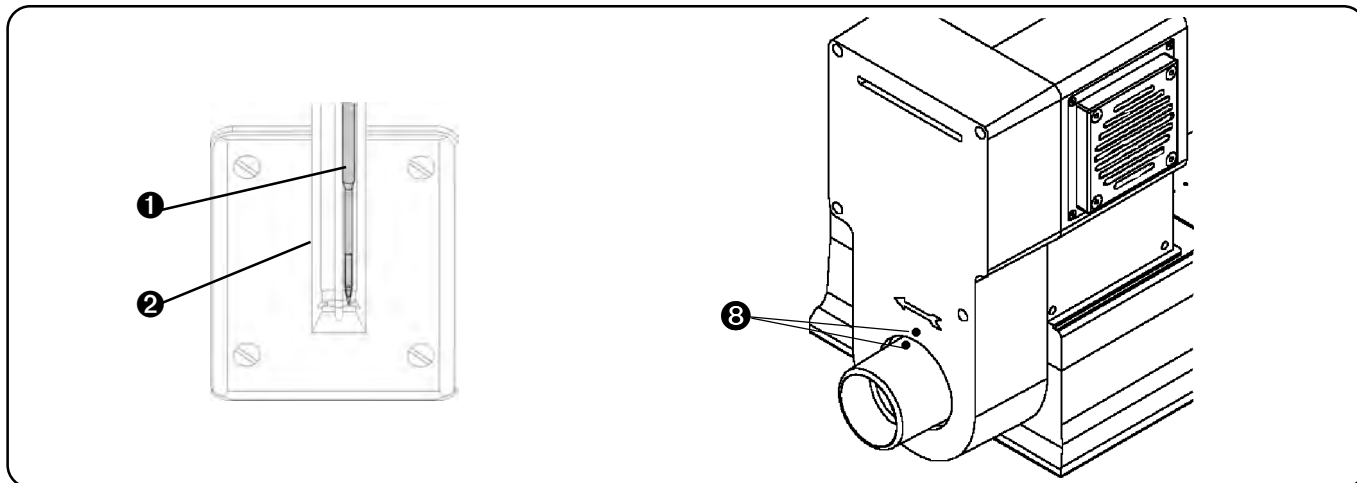

### 2. ADJUSTMENT OF THE SHIFTER

1. Machine must be in the home position.  
 2. Tilt the machine, lean it onto the support pin and look at the assembly of the main cam. There must be a minimal play  $x$  between the main cam shifting mechanism. If you see the mechanisms clash into each other, lose screws ❸ and take out the spring ❷. Loose screws ❹ and move arms ❾ ❿ from the main cam as much as possible. Check the minimal play  $x$  after the adjustment.

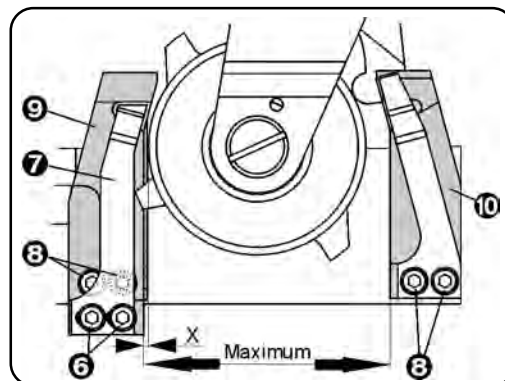

### 3. PRINCIPLES FOR MACHINE ADJUSTMENT

1. Before starting doing adjustments switch the machine into the service mode by pressing the emergency stop button on the machine head and releasing it again. Press

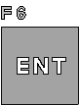
the button  ❶ on the control panel afterwards. "Service mode" message appears on the display.

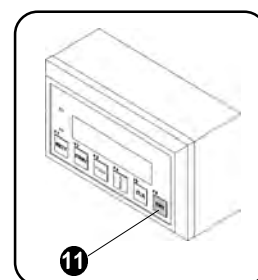

**WARNING!** THE MACHINE CANNOT START OPERATION BY PRESSING THE FOOT PEDAL IN THE SERVICE MODE!

2. Press  button to go back onto the main screen.

## E - MACHINE ADJUSTMENTS

### 4. NEEDLE BAR

#### 1. *Position of the bell-shaped eccentric*

Turn the hand wheel ⑤ and loose the fastening screw ① 1 in the bell-shaped eccentric ②. Keep turning the hand wheel until the needle bar reaches upper position. Pulley screw ③ on the main shaft is on the same level with the bearing cage screws ④ Tighten the fastening screw ①.

**NOTE:** In order to check this device (home position), turn the hand wheel forward and backward. The needle bar must go down, not up. The needle ⑩ must start sewing in the direction of the arrow – see the picture. After the adjustment of the eccentric, check the position of loopers and main shaft with the upper shaft. (See loopers adjustment).

#### 2. *Setting up the height of the needle bar*

With the machine in home position, set up the needle bar ⑨ with the gauge ⑥ to the height of 16 mm (5/8") from the top of the throatplate ⑦ to the low edge of the needle eye.

Loosen the setscrew ③ and move the needle bar up or down as necessary.

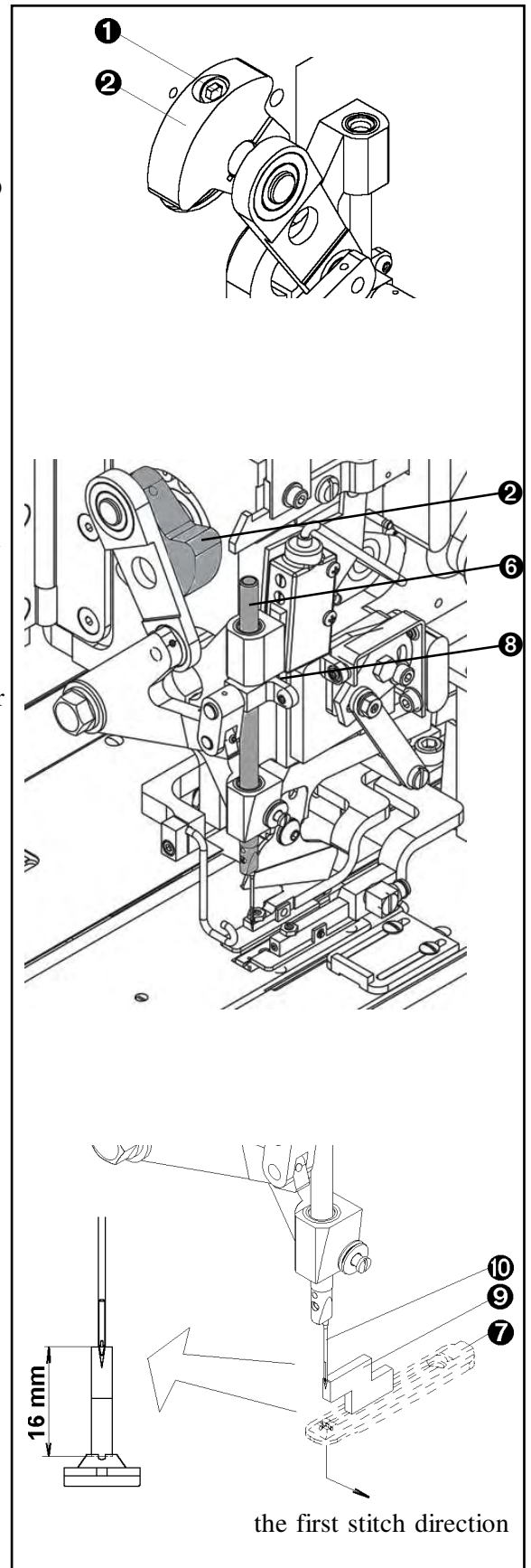
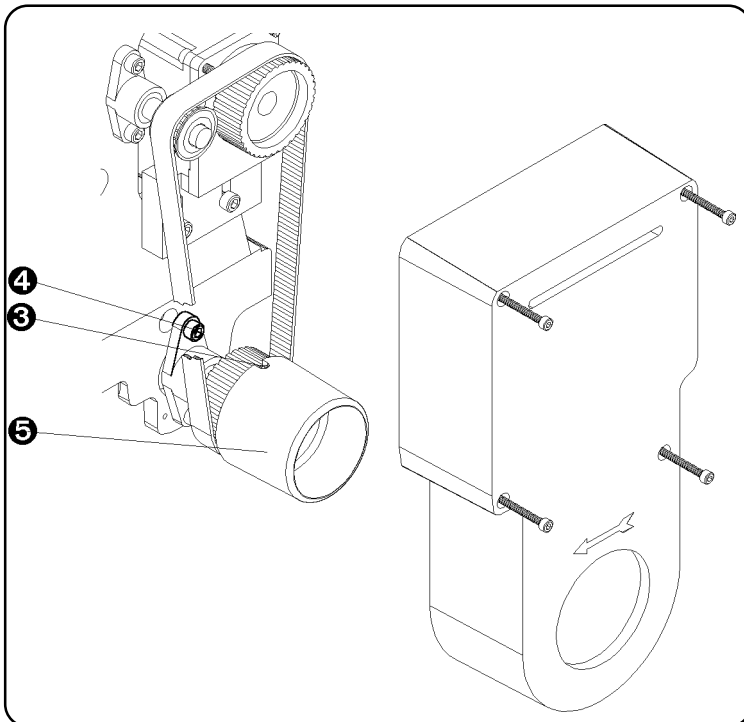

## E - MACHINE ADJUSTMENTS

### 5. BITE

Before setting up the bite, dismantle pulley cover ② and head cover ①.

#### 1. Bite cam

- a) Check that the machine is in home position.
- b) Tilt the machine head onto the support pin ⑦. If the adjustment is correct, the second setscrew ③ of the cam ⑨ (counter-clockwise) must fit vertically onto the bedplate casting.
- c) Preparatory adjustment of the bite is done by tightening the setscrew ③ of the cam ⑨ on the shaft.

The needle ⑩ must travel even distance when moving up and down from the up dead centre.

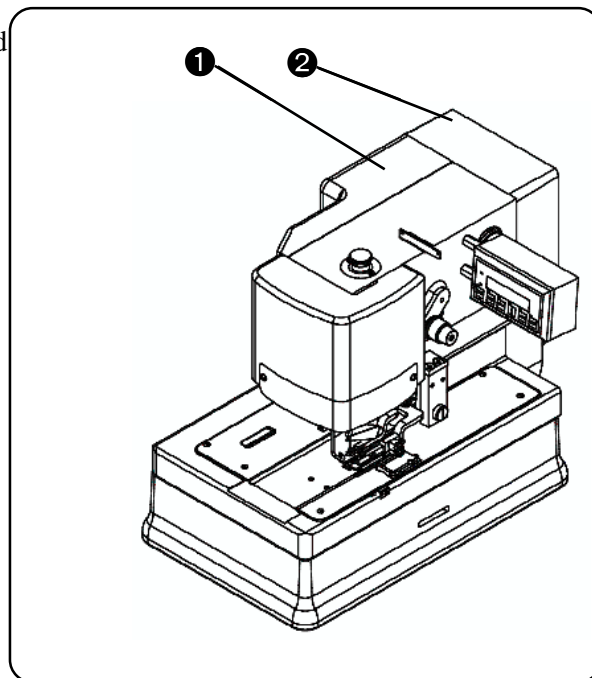

⑧ ⑨

Needle upper position

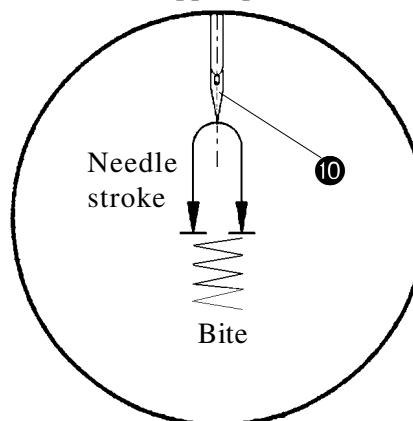

## E - MACHINE ADJUSTMENTS

### 2. Setting up the width of the bite

Tilt the machine head from the support pin back into the sewing position. The width of the bite is set up from the rear side of the machine head from the space below the motor. Hence the head cover needs to be dismantled.

The machine S-4000 is assembled with the throatplate **11**, having the bite range from 1.5 mm (1/16") to 2.3 mm (3/31"). The width of the bite is adjusted as follows:

- loosen the adjusting screw **12**
- lift up the drawbar **13** to get a wider bite
- bring the drawbar **13** to get a narrower bite
- tighten the adjusting screw **12**

### 3. Setting up the bite in the throatplate

- the machine must be in the home position – loosen the tightening screw **14** on the bite lever **15**
- turn the hand wheel to lower the needle bar into the bottom dead centre and move it towards the right side throatplate groove **11**
- tighten the tightening screw **14**
- turn the hand wheel to check that the needle **10** has same play on both sides of the throatplate groove.

**NOTE:** This is just a reference adjustment.

For final adjustment loosen the eccentric screw **16** and turn slowly the eccentric screw **17** Position the needle in such way that the play is same on both sides of the throatplate groove. Tighten the eccentric screw **16**.

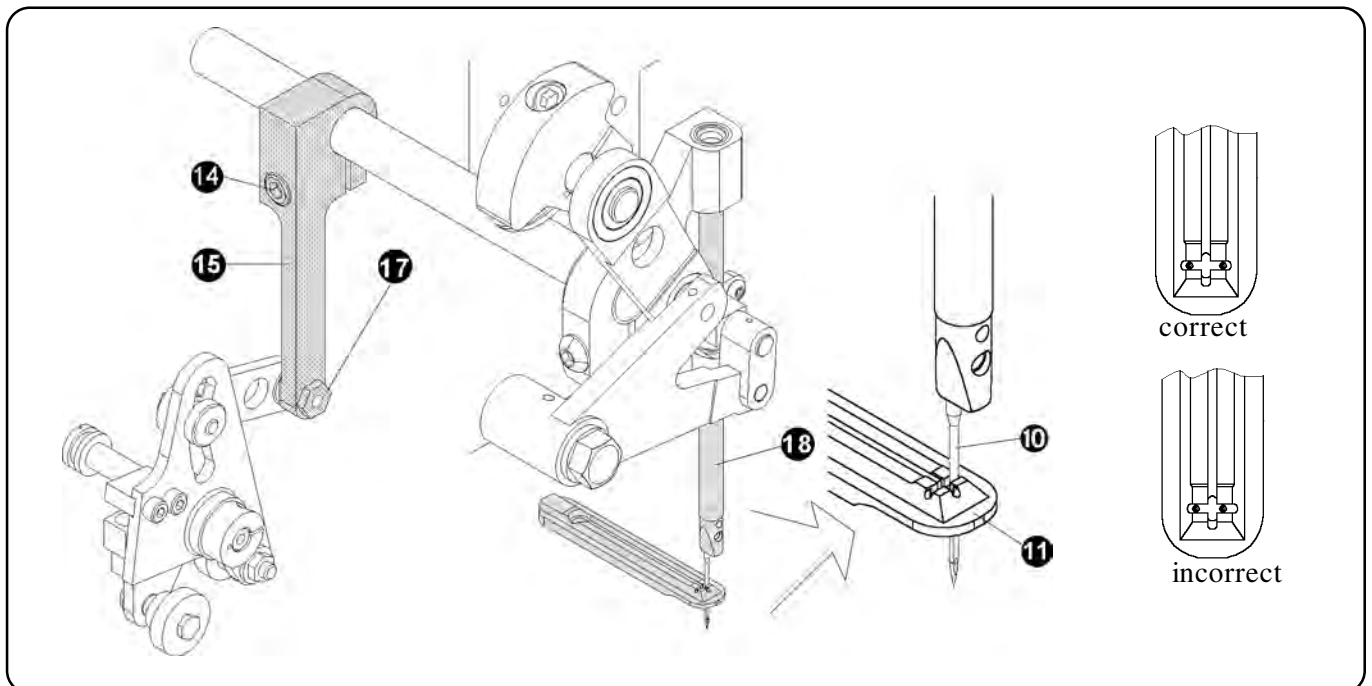
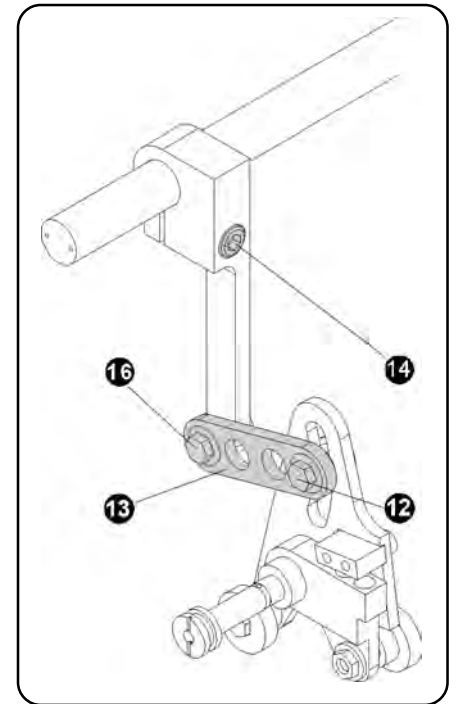

## E - MACHINE ADJUSTMENTS

### 6. FEEDING

1. Tilt the machine head onto the support pin.
2. Adjustment of feeding wheels  
Turn the hand wheel counter-clockwise until the guiding spring snaps into the shifter left arm notch. The feeding lever is on the very top point of the feeding cam. Dismantle the gearwheel safety cover and loosen the screws **1**, **2** on the horizontal gearwheels and the crank drive screw **3**.
3. Loosen two adjusting screws **4** in the right ring **5**.  
Pressing the end of the feeding shaft **6** against the right ring **5** you adjust the distance between the left ring **7** and the end of the feeding shaft **6** to 11 mm. Tighten the adjusting screws **4** on the right ring **5**. This is the right tension adjustment of the left ring on the shaft.
4. Place the right gearwheel **8** into the gearing with the vertical wheel **9** secure its position with setscrews **1**.
5. Turn the hand wheel counter clockwise until the guiding spring snaps into the shifter right arm notch. The feeding lever is on the very bottom point of the feeding cam. Place the left gearwheel **10** into the gearing with the vertical wheel **9** secure its position with setscrews **2**. Push the crank drive towards the left gearwheel **10** and secure it with the screw **3**.

You have set up the position of the feeding wheels. Turn the hand wheel to finish the sewing cycle and bring the machine into the home position. Mount the wheel safety cover on.

6. The feeding always starts, in other words the clamp plate moves, when the needle is out of the fabric, and it is in the position when the needle tip is right above the fabric.
7. Use a sheet of paper to do the adjustment. You will clearly see needle punctures.

If the adjustment is incorrect, set the machine into such a sewing position so that the guiding spring snaps into a shifter arm notch.

Loosen the screws on the feeding cam **11** and adjust its position so that the clamp plate moves in the moment of the needle being out of the fabric (above the paper). Tighten the setscrews.

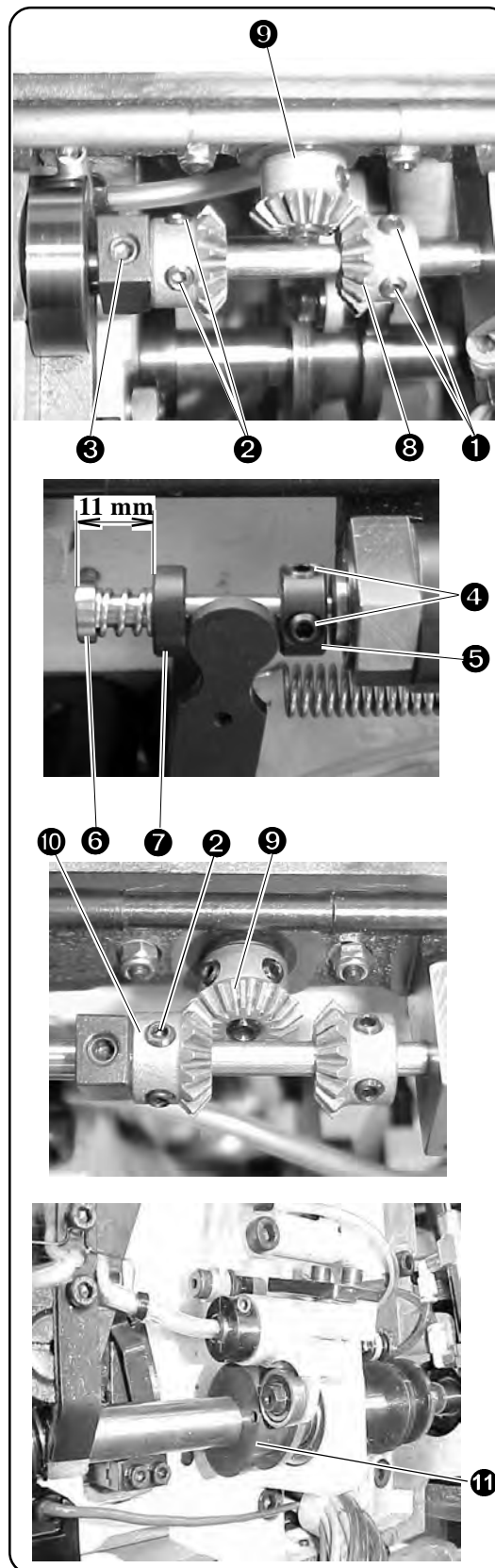

## E - MACHINE ADJUSTMENTS

### 7. CLUTCH

Clutch pressure is set up by the manufacturer. Under normal circumstances, it is not necessary to adjust it. The correct torque is 0,42 Nm.

Hold the nut **1** and tighten the adjusting screw **2** with a torque wrench. Adjust the torque so that is even on both sides of the clutch.

**NOTE:** If you do not have a torque wrench available, set ends of both screws so that screw-threads overlap nuts edges of 1,5 mm.

**CAUTION:** If the torque is too small, fabric will not be fed in correctly.  
 If the torque is too big, it can damage some parts (gearwheels).

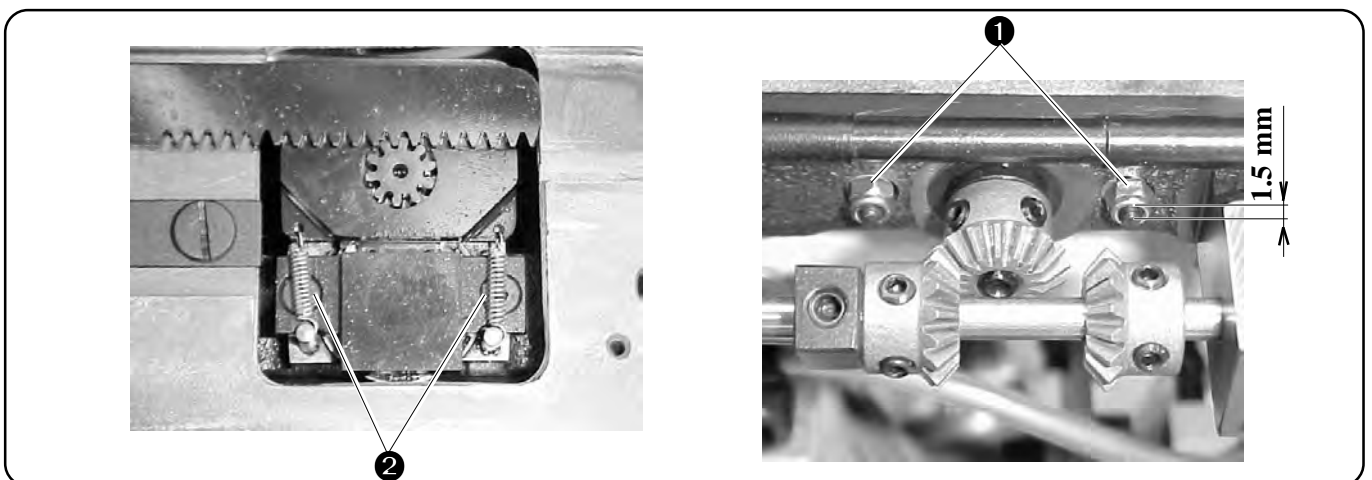

### 8. STITCH DENSITY

Adjust position of the feeding rod **3** in the density lever groove **4** in order to achieve right stitch density.

**Increasing stitch density 1:**

- a) Loosen the hexagonal screw **5** and move the rod **3** from the bedplate. That will increase the stitch density.
- b) Tighten the hexagonal screw **5**.  
 Maximal stitch density is 14 stitches per 10 mm.

**Reducing stitch density 2:**

- a) Loosen the hexagonal screw **5** and move the rod **3** towards the bedplate. That will reduce the stitch density.
- b) Tighten the hexagonal screw **5**.  
 Minimal stitch density is 3 stitches per 10 mm.

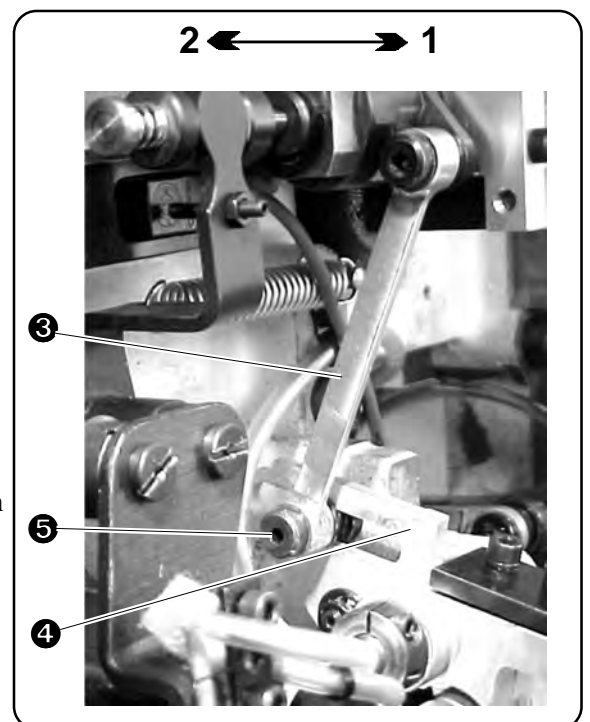

## E - MACHINE ADJUSTMENTS

### 9. LOOPERS ADJUSTMENT

Before the adjustment, follow the instructions below:

- Turn the hand wheel and see carefully the position of the connecting rod **1** on both extreme positions of the looper movable arm **2**. Angle A **3** and angle B **4** should be even.
- If the angles are not even – loosen the hexagonal erection bolt **5** and turn the eccentric adjusting bolt nut **6** as necessary. Tighten the hexagonal erection bolt **5**.
- Turn the hand wheel to set the needle bar to the upper dead centre.
- Check that the needle is straight.
- Tilt the head onto the support pin and check that the mark **7** on the looper cam **8** is on the left side. If it is on the right side, take the cam out and turn. Place the machine head back to the operation position.
- Remove the cover **9**, disconnect pneumatic pipes from the clamping cylinder and take the clamping assembly **10** out. Remove the throatplate **11**, trimming hook cover **12** and trimming hook. Dismantle the holders with loopers.

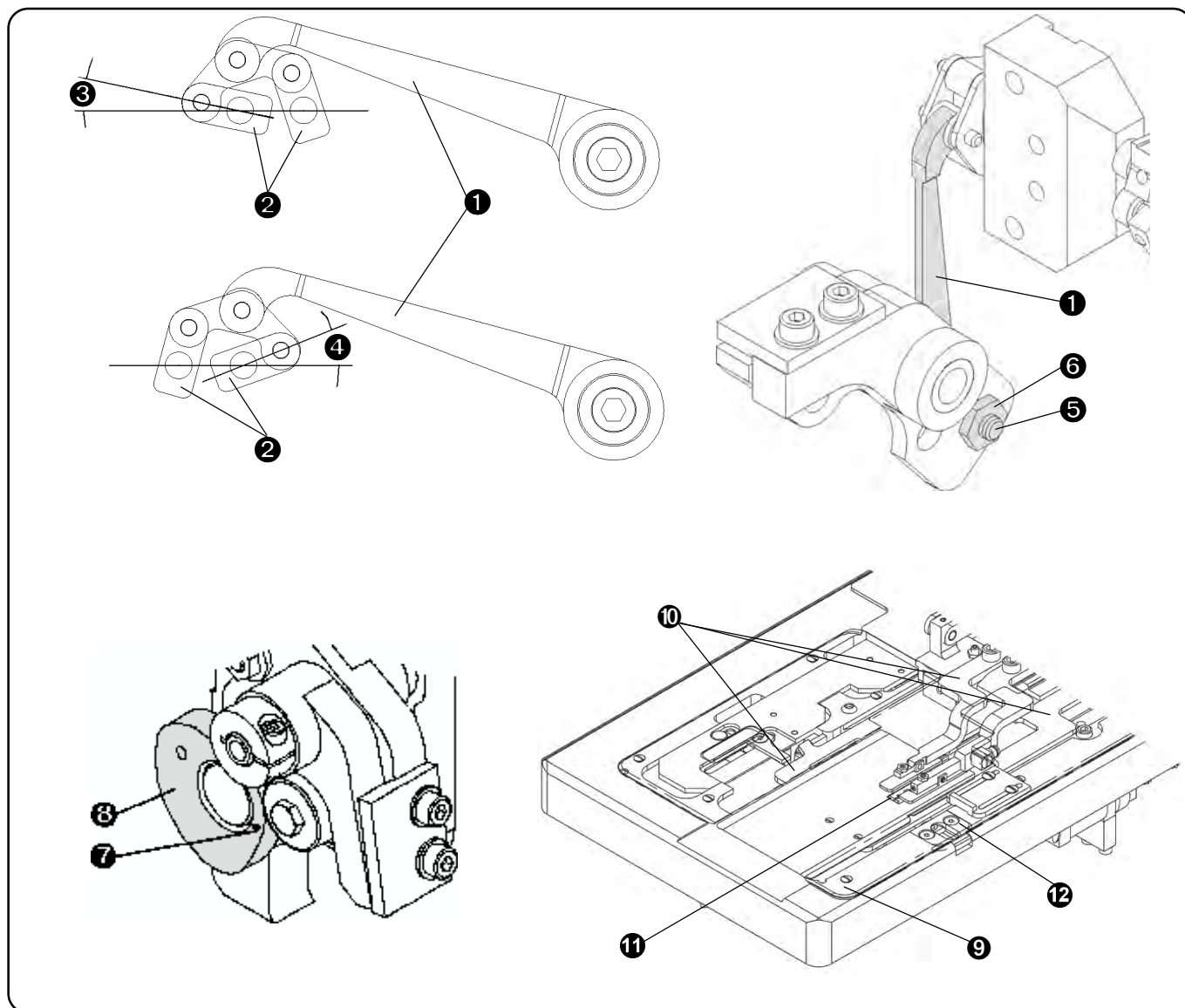

## E - MACHINE ADJUSTMENTS

### Adjustment of the first looper

1. With the machine being in the home position, loosen the looper cam **8** screws **13** and set it to the lowest position.
2. Loosen the adjusting screw **15** and turn the looper so that it is vertically towards the opening in the holder.
3. Install the holder with the first looper **14** onto the shaft.
4. Loosen the looper holder screw **16** and move the holder so that the needle goes through the centre of looper opening. There must be 0,4 mm play between the needle and the looper opening. Tighten the looper holder screw **16**.
5. Loosen the looper screw **15** and turn the looper **14** towards the needle so that there is 0,1 mm play between the needle and the looper tip.
6. Turn the hand wheel counter clockwise. Once the needle comes back to the home position from the bottom dead centre, insert the gauge **17** market **1** (wider side of the gauge) between the needle bar holder and the needle bar clamp.
7. Check that the looper tip is centered on the needle and that it is 1 mm above the needle eye.
8. If it is not centered – loosen the looper cam screw **13** and hold it. Turn the hand wheel slightly counter clockwise if the distance between the looper tip and the needle eye is larger than 1 mm; clockwise if the distance is smaller than 1 mm. Tighten the looper cam screw **13**.
9. If the looper cam has been re-adjusted, it is necessary to check the play 0,4 mm between the needle and the looper opening.

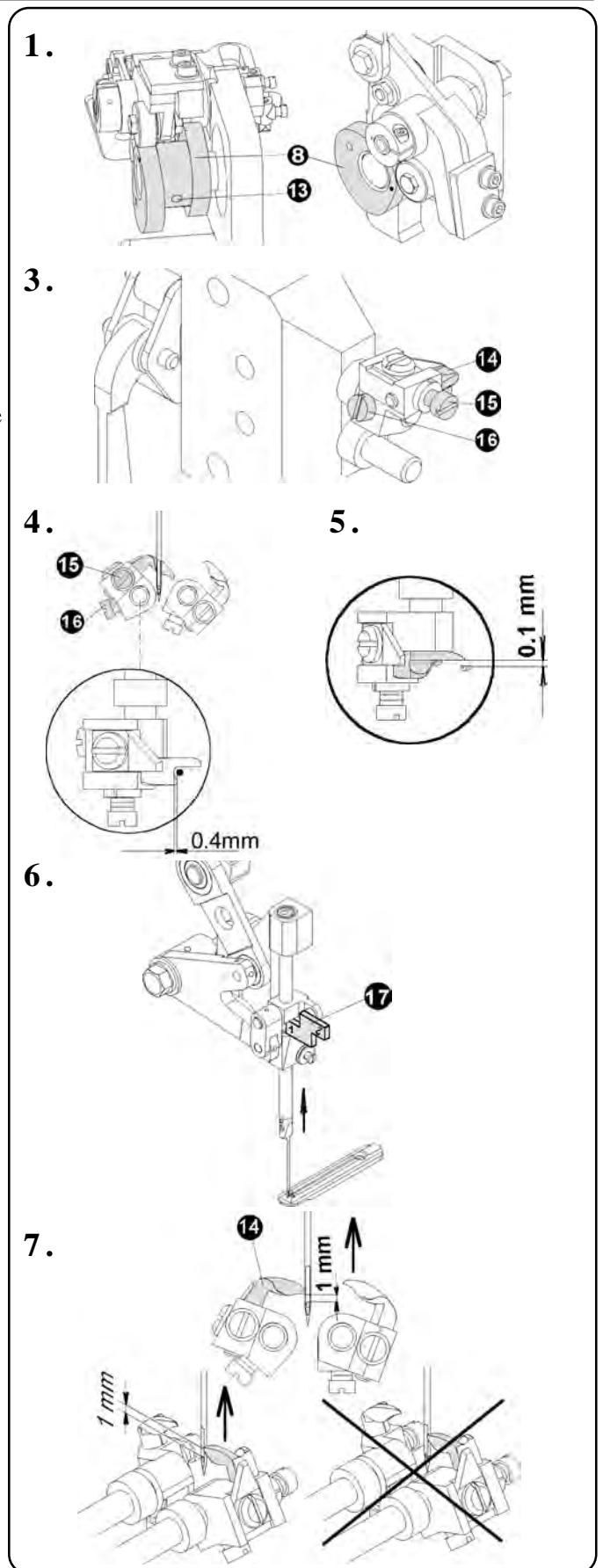

## E - MACHINE ADJUSTMENTS

### Adjustment of the second looper

10. Insert the second looper **18** onto the looper shaft.
11. Loosen the looper holder screw **19** and move the holder so that the needle goes through the centre of looper opening. There must be 0,4 mm play between the needle and the looper opening. Tighten the looper holder screw.
12. Loosen the looper screw **20** and turn the looper **18** towards the needle so that there is 0,1 mm play between the needle and the looper tip.
13. Turn the hand wheel counter clockwise. Once the needle comes back to the home position from the bottom dead centre, insert the gauge **17** market 2 (narrower side of the gauge) between the needle bar holder and the needle bar clamp.
14. Check that the looper tip is centered on the needle and that it is 1 mm above the needle eye.
15. When adjusting the looper cam, it is necessary to check the set up of the first looper again.

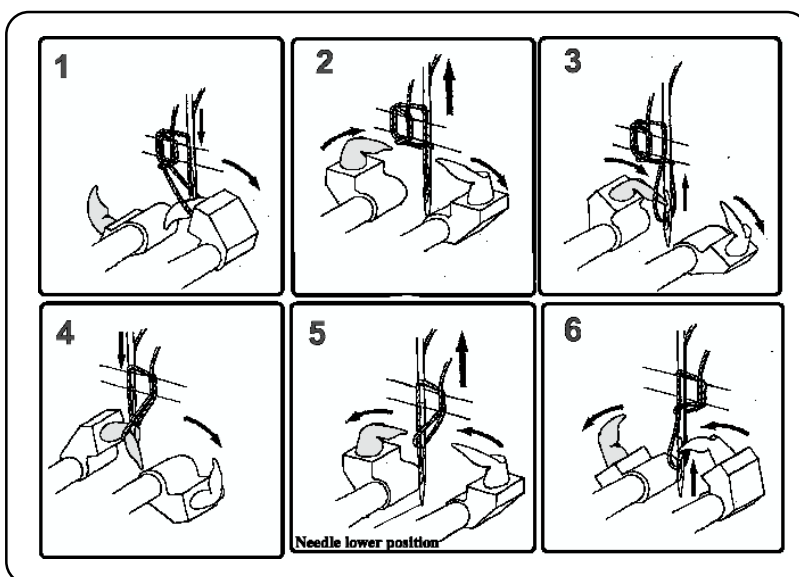
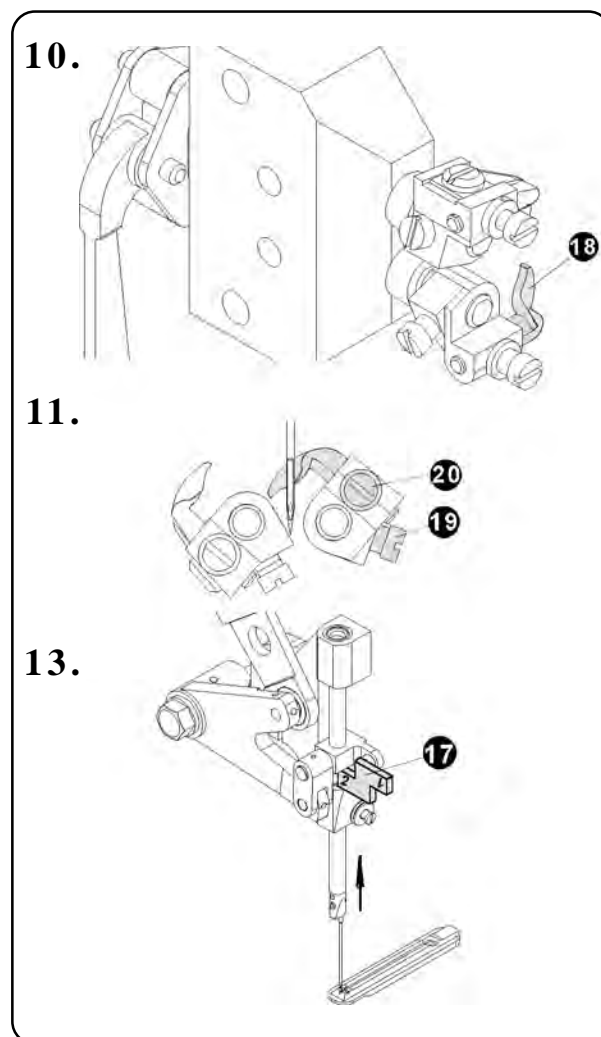

## E - MACHINE ADJUSTMENTS

### 10. HOME POSITION OF THE CLAMP PLATE

1. Home position of the clamp plate before sewing:
  - a) conical gear wheels **1** on the feeding shaft are **disjointed** by the vertical conical gear wheel.
  - b) clamp plate is placed on the right side (to the head casting)
2. If the feeding wheels are not disjointed, proceed as follows:
  - a) loose the worm gear wheel screws **2** of the main shaft, hold the worm gear and turn the hand wheel counter clockwise or clock wise as necessary. Tighten the screws.

**Note:** If the adjustment is correct, the conical wheels must be disjointed in the home position and the first needle puncture/stitch must go into the right throatplate groove.

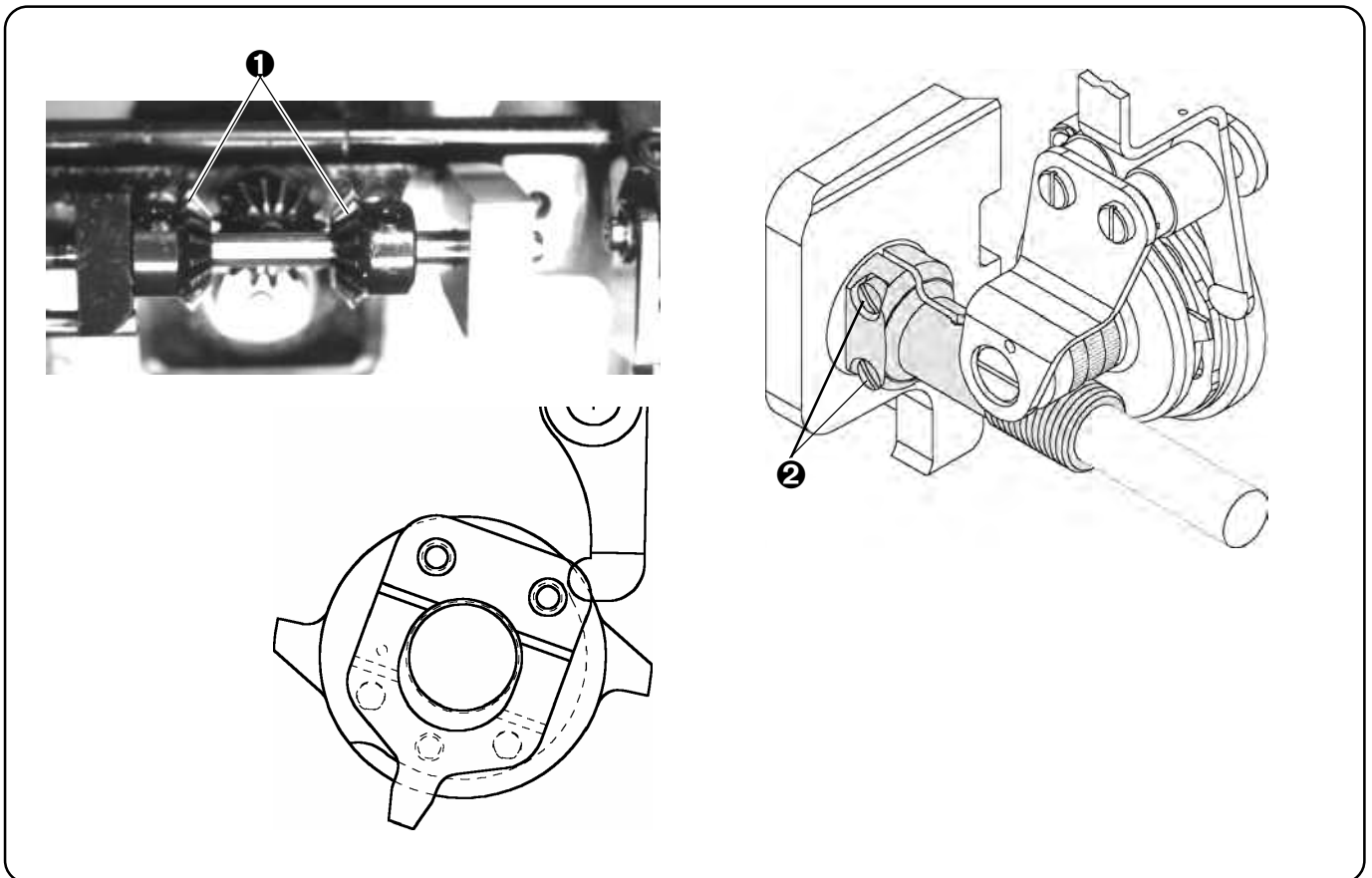

## E - MACHINE ADJUSTMENTS

### 11. CLAMP PLATE ADJUSTMENT

1. If the distance between the clamp plate cover **1** and the throatplate edge **2** is too large, proceed as instructed in items 2 and 3. Recommended distance – 0,2 mm.
2. Loosen the nut **3** in the lever groove **4**.
3. Insert the gap gauge 0,2mm into the gap between the clamp plate cover **1** and the throatplate edge **2**. Move the clamp plate **5** onto the gauge and secure the position by tightening the nut **3**.

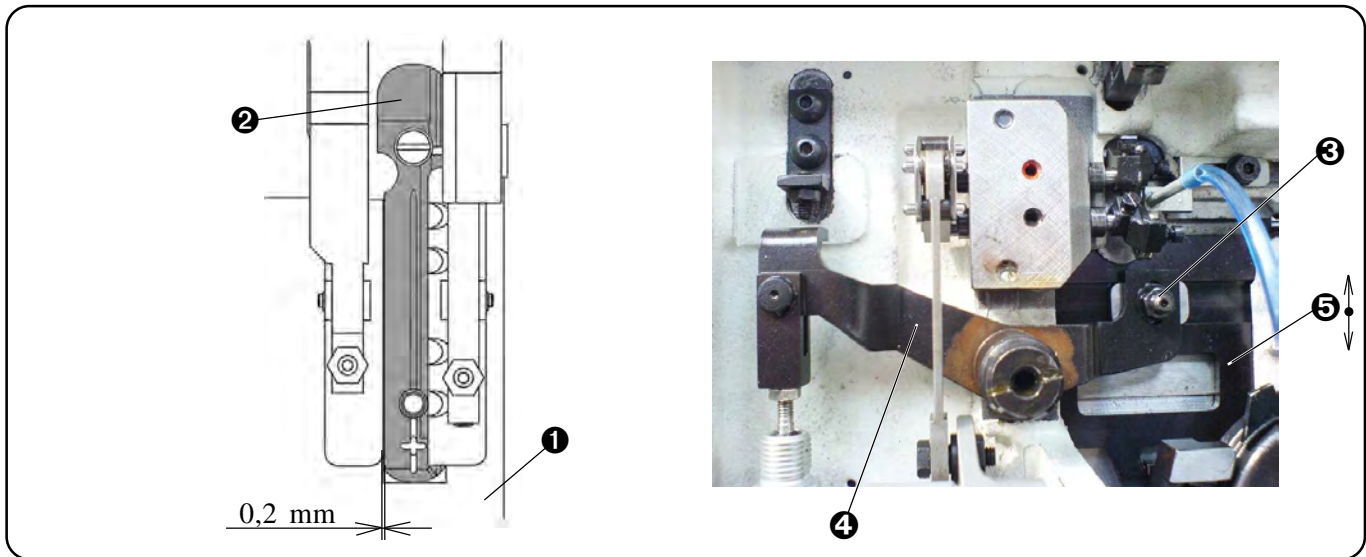

### 12. TRIMMING MECHANISM ADJUSTMENT

If the mechanism does not trim properly, do the following:

\* Disconnect the air supply, close the clamp feet and move the clamp plate to the left from the shear edge.

1. Check the shear knife **1** and throatplate edges **2**. If they are damaged, they can be sharpened or replaced with new parts.
2. Push the trimming mechanism from the top by your hand **3** and check whether the shears slightly overlap along the shear edge. If they do not overlap, loosen the screw **4** M4 and turn the studs **5**. Secure the position by tightening the screws M4.

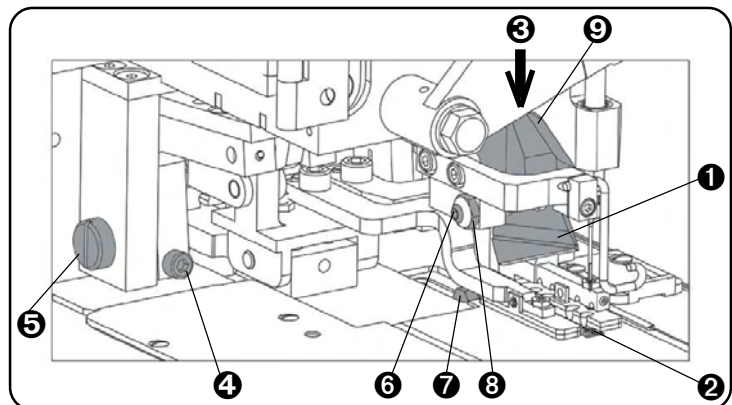

## E - MACHINE ADJUSTMENTS

3. Secure the correct position of the mechanism with the stopper ⑥ in the upper dead centre and the stopper ⑦ in the plate in the bottom dead centre.

4. Correct adjustment of the stop screw ⑥:

- loosen the nut ③
- turn the stop screw ⑥ until it touches the cutting lever ⑨
- move the mechanism ③ by your hand to check whether the motion has not been embarrassed
- secure the correct position by tightening the nut ③

5. Correct adjustment of the stopper ⑦ in the bottom dead centre:

- tilt the machine head
- loosen the screws ⑩
- with your hand push the trimming mechanism into the bottom dead centre
- push the stopper ⑦ onto the knife ① and secure its position by tightening the screws ⑩.
- check again, whether the motion has not been embarrassed

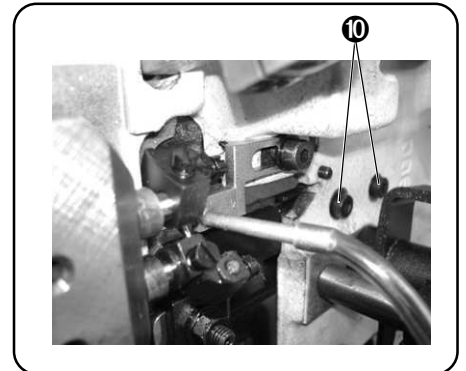

6. Take a blank sheet of paper and insert it into the trimming mechanism. Push the trimming mechanism with your hand. The cut must be neat. If it is not, proceed as per the instructions 1 – 6.

### 13. ADJUSTMENT OF THE CLAMP PLATE CHANGE-OVER

Standard set up of the device is 2 mm. It is the minimal value for the knife to go through firmly. With such set up following results can be achieved:

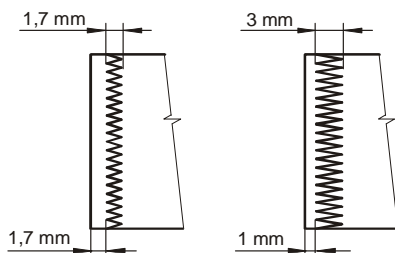

If you wish to shorten the distance between stitches and cut fabric, you can adjust the value with the nut ① and the screw ②; to 3 mm at the most. Otherwise the knife may cut stitches.

**NOTE:** The set value must never be smaller than 2 mm, because of the knife, which can get damaged in such case!

Adjustment instructions:

- tilt the machine head
- loosen the nut ①
- turn the screw ② and set up the required distance
- secure the position with the nut ①

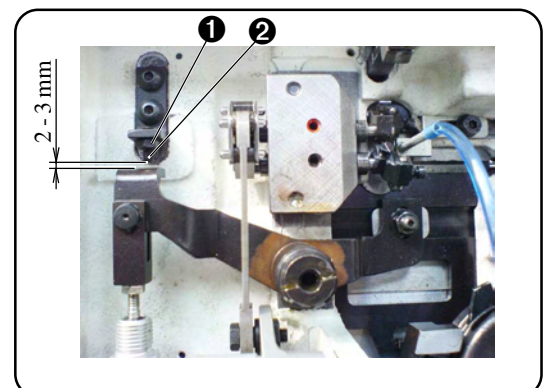

## E - MACHINE ADJUSTMENTS

### 14. ADJUSTMENT OF MACHINE HEAD CLAMPING FOOT

#### 1. *Adjustment of the uplift*

Adjustment must be done with air switched on. Make sure the foot is open. If it is not, press the feet button to activate it.

- loosen the nut ❶
- turning the screw ❷ clockwise, the clamping foot mechanism ❹ moves away from the clamping mat ❸. Turning the screw counterclockwise, the mechanism comes forward.
- tighten the nut ❶

**NOTE:** once the foot uplift is adjusted and the machine is in its home position, the clamping foot should not be higher than the needle tip.

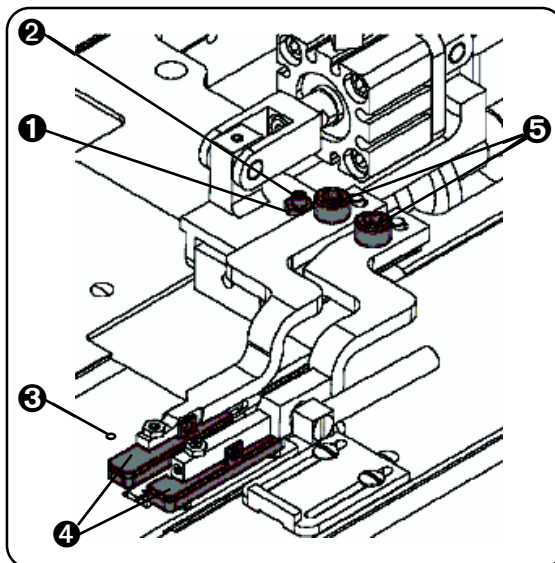

#### 2. *Adjustment of the clamping foot directing at the centre of the needle*

Check that the foot is closed. If it is not, press the feet button.

- turn the hand wheel to make sure the needle does not hit the clamping feet ❹. If they do, then take the following steps:
- press the feet button to open the foot
- loosen the screw ❺ and move the foot arm away from the needle and tighten the screw ❺ again.
- with the foot closed, turn the hand wheel again to see that the adjustment is correct. In that case the needle must not hit the foot.

#### 3. *Adjustment of pressure*

To ensure a good quality sewing, it is important the clamp feet hold the fabric along its entire length.

- close the feet ❻ by pressing the feet button.
- loosen the nuts ❼ and turn the screw ❸ to set the feet in the right position.
- tighten the nuts ❼.

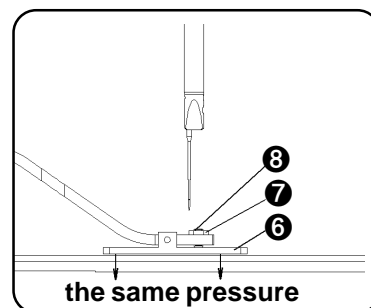

### 15. THREAD DRAW OFF

#### 1. *Adjustment of the end thread*

If there are some skipped stitches at the beginning of sewing or the cycle is not finished, do the following:

- loosen the screw ❶
- turn the draw off lever ❷ counterclockwise so that the remaining thread in the needle gets longer.

#### 2. *Stitching*

Follow the above-mentioned procedure in cases some stitches skip during sewing process. Turn the draw off lever ❷ counterclockwise. It enlarges the loops at loopers, which then catches the stitches better.

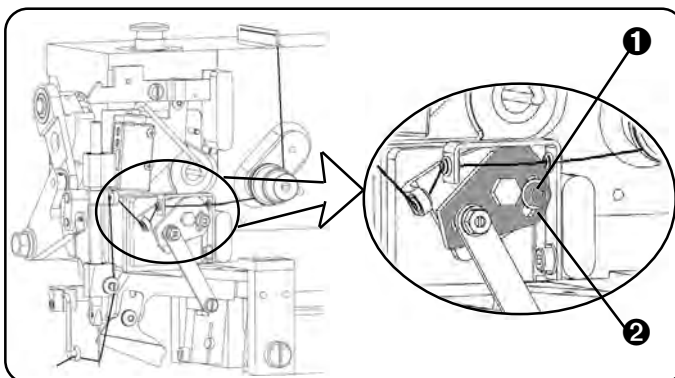

## E - MACHINE ADJUSTMENTS

### 16. THREAD TENSION

Correct thread tension affects the final appearance of sewing. The tension changes with the change of material sewn. The thinner and the more elastic material is, the wider the thread tension must be opened. When replacing any part affecting the thread passing, check the smooth finish of surfaces getting in touch with thread.

- Turn the tension knob ❶ clockwise to increase the thread tension.
- Turn the tension knob ❶ counterclockwise to decrease the thread tension.

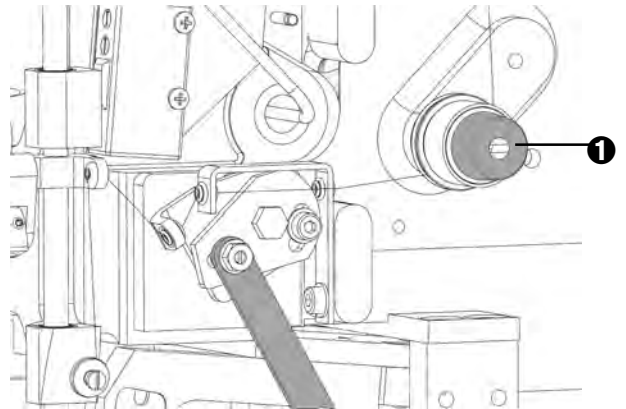

**NOTE:** If there is too much thread tension when sewing light and elastic materials, the workpiece can deflect in the sewing area and the final look is not nice.

### 17. THREAD TRIMMING

The trimming mechanism ensures correct trimming of all threads after finishing the last stitch. The trimming hook, which moves in the direction of the arrow, pulls both thread ends A, B. Once the hook is close to the uplift, it guides the left side of the loop A on the knife edge. The thread is trimmed.

#### 1. Adjustment of the trimming cylinder

- a) tilt the machine head onto the support pin and close the air supply. Push out the piston ❶ of the cylinder ❷ to the possible limit.
- b) check that the lever ❸ does not overlap the surface of the plate ❹. If the lever is above the surface, do the following:
  - c) loosen the screw ❻.
  - d) loosen the nut ❺ and by using some tools (pliers), turn the piston ❶ of the cylinder ❷ clockwise. It will ensure the lever ❸ is in the right position.
  - e) tighten the nut ❺ and the screw ❻. Check, there is no axial play on the shaft ❼ after the adjustment.
  - f) if there is some play on the shaft, loosen the screw ❻, move the shaft ❼ to the left so that the lock ring 8 touches the cut in the plate ❸. Move the lever to the right until it stops and tighten the screw ❻.

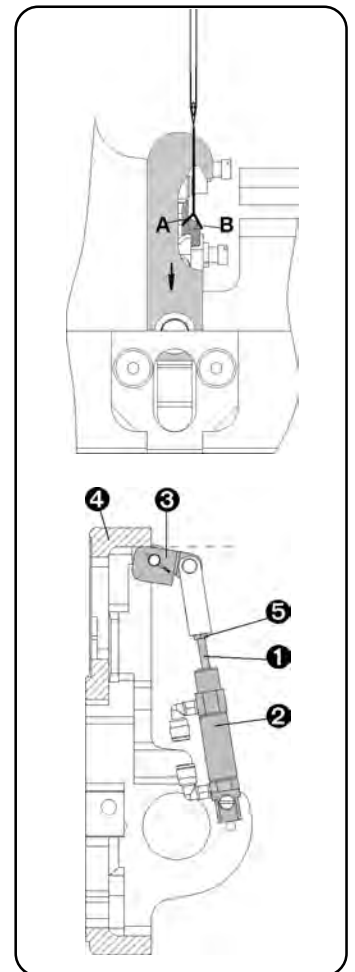

## E - MACHINE ADJUSTMENTS

### 2. Adjustment of the trimming hook

- press the piston **1** of the trimming cylinder **2** down to the maximal limit and loosen the screw **9** of the trimming actuator **10**.
- turn the trimming actuator **10** and set the 1.0 mm play between the throatplate and the trimming hook tip.
- tighten the screw **9** of the trimming actuator **10**.
- open the air supply and by switching the trimming cylinder valve check that the actuator **10** does not hit the bedplate casting.

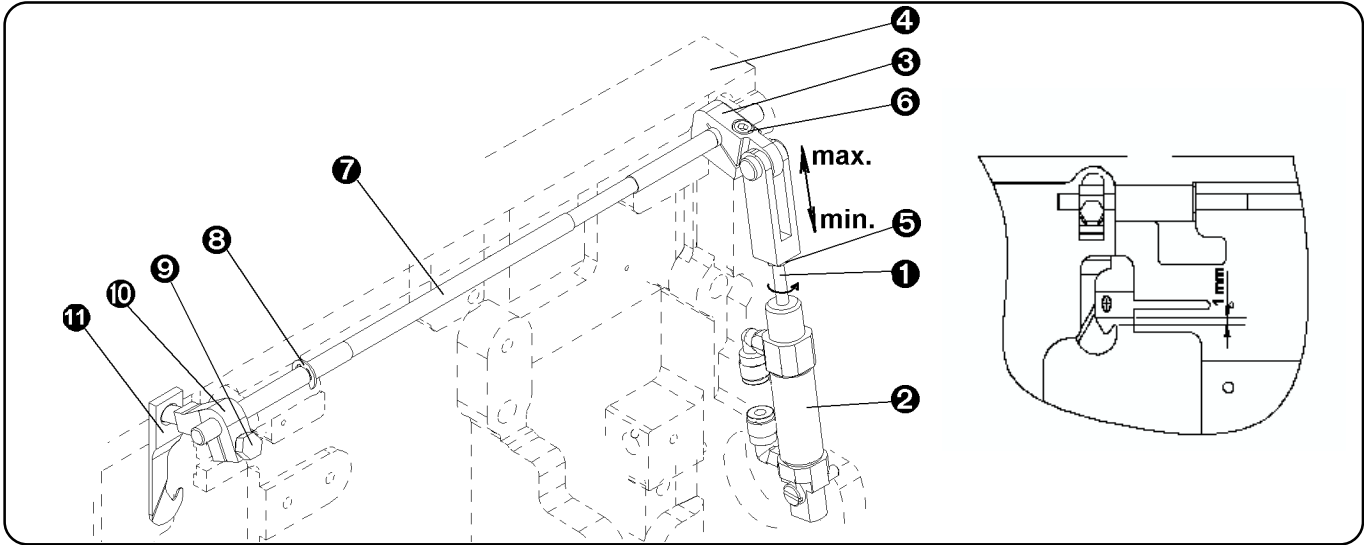

## 18. CUTS-OFF BLOW OFF

Cuts-off are blown off through openings in the right arm of the clamping feet by air forced in.

### 1. Regulation of airflow

The airflow can be regulated with a choke placed on YV7 branch.

Turn the screw clockwise to reduce the airflow. Turn the screw counterclockwise to increase the airflow.

### 2. Regulation of air blow period

This function is operated directly from the operating panel display.

Press F1 → F3 → Mater.blow. The range of air blow is 10-1000 ms.

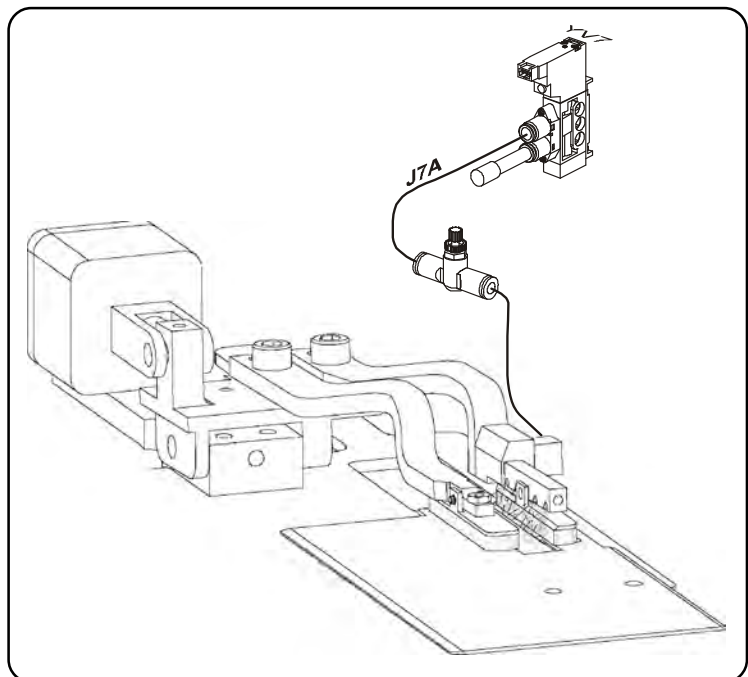

## E - MACHINE ADJUSTMENTS

### 19. THREAD BLOW OFF (SPECIAL ACCESSORY)

Thread blow off is ensured by a pipe placed in the bedplate under the throatplate and air forced into the pipe.

1. **Regulation of airflow**

The airflow can be regulated with a choke placed on YV8 branch. Turn the screw clockwise to reduce the airflow. Turn the screw counterclockwise to increase the airflow.

2. **Regulation of air blow period**

This function is operated directly from the operating panel display. Press F1 → F3 → Thread blow Off. The range of air blow is 10-1000 ms.

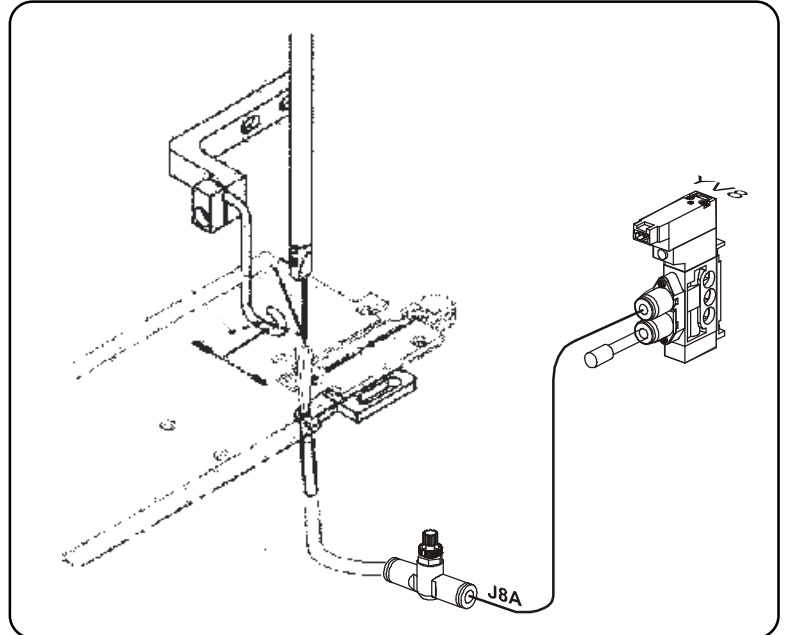

### 20. ADJUSTMENT OF STOP SENSOR POSITION

Follow the instructions to adjust the position of the sensor:

1. Switch the machine over into the service mode – see section E2.
2. Turn the hand wheel until the stop disc thumb **1** is placed vertically above the sensor **2**.
3. Loosen the sensor screws **3** and move the holder **4** to the right to the limit position. Tighten the screws **3**.
4. Loosen the screw M3 **5** and adjust the position of the sensor so that the stop disc thumb **1** is center lined with the sensor marker **6**. The indicator **7** on the sensor lights up red.
5. Tighten the screw M3 **5**.
6. Tilt the machine head back into operating position.
7. Press F6 on the control panel to bring the machine into the operation mode.
8. Switch the machine on and check the correct setting. The needle bar stops in the home (upper) position.

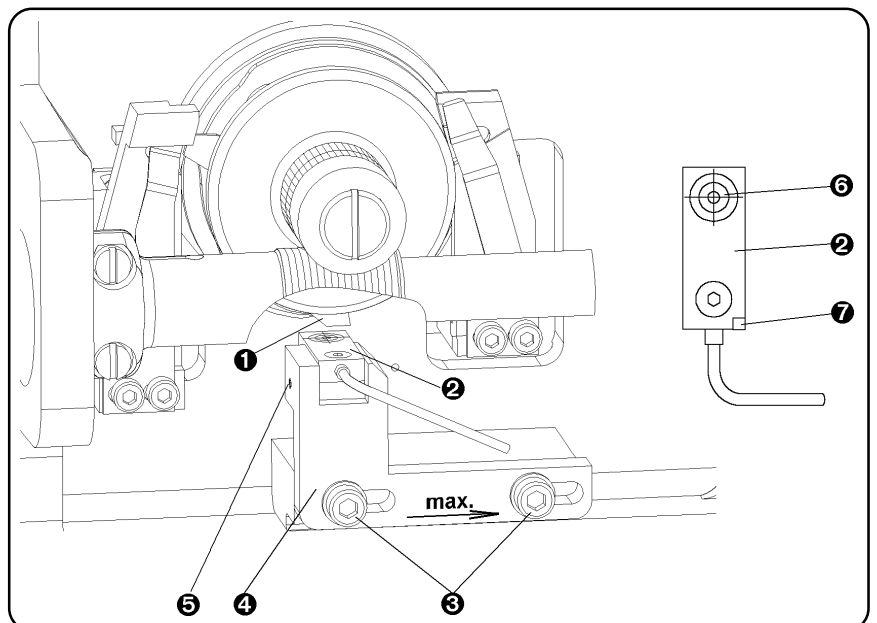

## E - MACHINE ADJUSTMENTS

### 21. REPLACEMENT OF THE BELT

1. Dismantle the pulley cover **1** by loosening the screws M4 **2**.
2. Turn the hand wheel **3** to set the position of the shaft so that the screw **4** on the pulley **5** levels the screw **6** on the bearing housing.
3. Secure the position with the holder 24.0030.0.000 **7**, which is a part of the accessory. With the screw **6** mount the holder to the bearing housing.
4. Turn the needle bar shaft pulley **8** until the needle bar comes to the upper position.
5. Secure the position with the holder 24.0024.0.000 **9**, which is a part of the accessory. With the screw **10** mount the holder to the bearing housing.
6. Turn the motor pulley **11** until the marks **17** on the motor flange and roller level.
7. Loosen the screws **13** on the motor flange **14** and the motor with the flange downwards in order to mount the belt.
8. Fit the belt **15** onto the pulley of the shafts **5**, **8** and motor pulley **11**. Move the flange **14** together with motor **16** upwards. This is the way to tension the belt **15**. Tighten the screws **13** to secure the flange. Make sure the marks **17** are leveled.
9. Remove the pulley holders **7**, **9**.
10. Check the adjustment by pressing the pedal. The needle bar must be in the top dead centre.
11. Small changes in the position of the needle bar can be changed in program parameters:

#### a) *needle bar just before top dead centre*

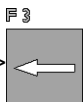
- press  =>  => „Ndl up pos ....imp“

- increase the value to reach correct position of the needle bar

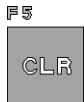
- press , to go back to the operation mode

#### b) *needle bar behind top dead centre*

- reduce the value to reach correct position of the needle bar

- press , to go back to the operation mode

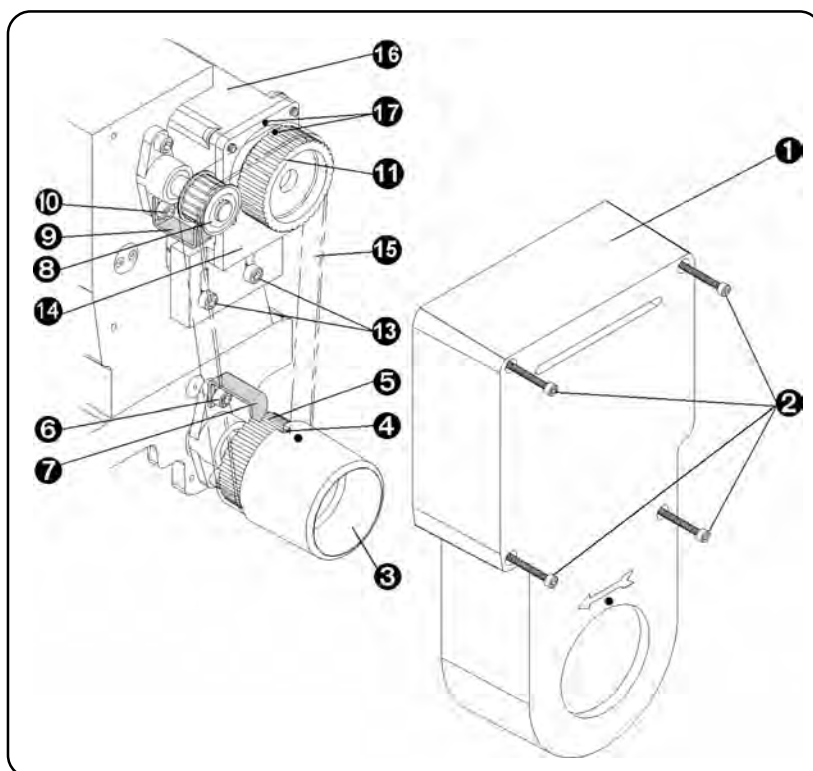

## E - MACHINE ADJUSTMENTS

### 22. PROTECTION DURING VOLTAGE FLUCTUATION (SPECIAL ACCESSORY)

The special accessory, guard voltage relay HRN-35 (VC1), is placed in the machine control box. It is pre-set and sealed from the manufacturer. If the supply voltage runs within the **required range**, the Led light **Un** on the relay lits **green**. Once the **upper limit is exceeded** (255V), the LED lights lits **red U<sub>≥</sub>**. If the **bottom limit is exceeded** (185V) the green LED light turns out and the **red LED light U<sub>≥</sub>** comes on. The control LED lights turn out if the voltage goes back to the required values. The delay of the relay activation is set up to a minimal value.

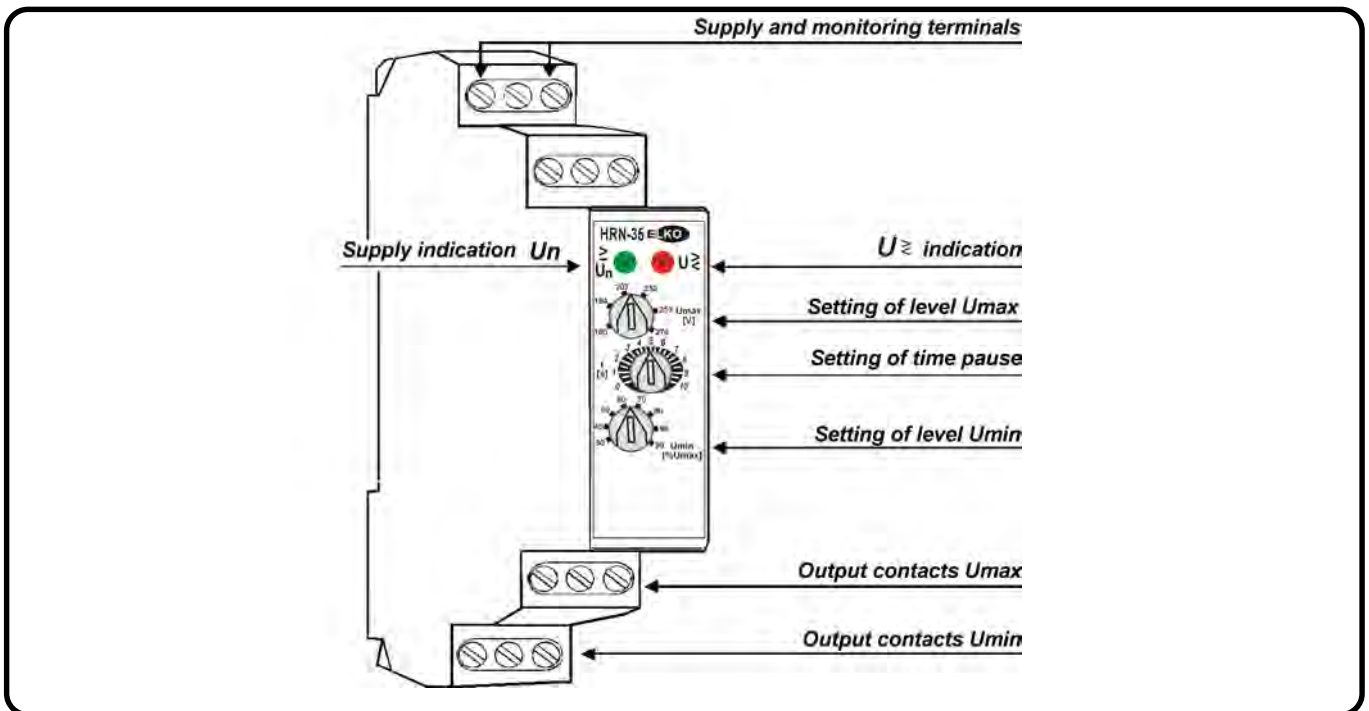

#### Exceeding upper supply voltage limit (255V)

- a) Turning the switch on , red LED light is on **U<sub>≥</sub>**. Supply voltage for electronics is cut off, the

display is not illuminated, the machine *cannot be turned on*.

- b) If the limit values of the supply voltage are exceeded during sewing, the machine automatically switches off in order to prevent control electronics from damaging. Once the value gets back to normal (185V - 255V), the machine can be switched on in a standard way (see section C1).

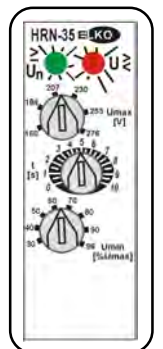

#### Exceeding bottom supply voltage limit (185V)

- a) Once the voltage drops below the bottom limit, the display shows the „LOW VOLTAGE“ message and the machine cannot be switched on.  
 b) If the supply voltage drops during sewing, the machine automatically stops and the display shows the „LOW VOLTAGE“ message.

**Once the voltage reaches the value 185V the machine can be switched on in a standard way** (see section C1).

## E - MACHINE ADJUSTMENTS

### 23. OPTICAL SENSOR - ADJUSTMENT

Loosen the holder of the optical sensor by loosening the screw M4 and adjust it in such way so that the ray of the optical sensor projected by the sensor meets the glass eye in throat plate and returns back to sensor. The sensor is switched on. After adjusting the sensor, tighten the screws on holder. In case the fabric is put in front of the glass eye for example, the control light of sensor is switched off.

To adjust the sensitivity of the sensor, use the control element on sensor. To decrease the sensitivity, turn this element into the left until the sensor light starts blinking. Then turn the element back until the light stops blinking. It is also possible to check the signal from sensor in output tests, see section **D5**.

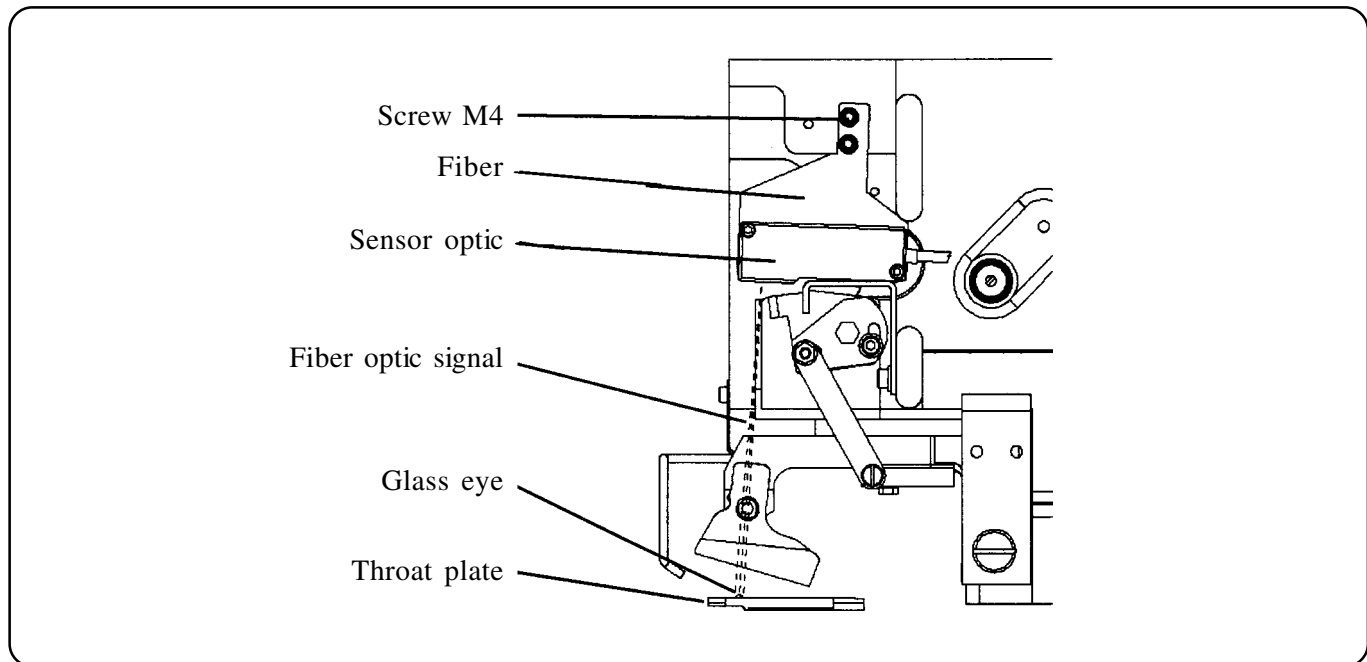

**Caution!** In order to ensure correct function of the sensor, keep the sensor eye clean, especially from lubrication.

## F - MACHINE MAINTENANCE

### Caution:

- Check the condition of electric cables; whether they are not damaged.
- Check that all safety covers are in good condition. Replace any damaged covers!
- Do not put your fingers in the sewing needle area in any cases!
- Do not modify the machine in any way, which interfere the safety factors.
- Do not plug in external lights or other devices into the electrical system of the machine

### Warning:

- Do not miss out regular maintenance checks.
- If the electricity supply breaks down, switch off the main switch.
- Do not damage, modify or remove the safety labels.
- Do not operate the machine impaired or intoxicated.
- Make sure the workplace is illuminated with at least 750 Luxs

### 1. CLEANING AND MAINTENANCE OF THE MACHINE

1. Switch off the power supply and disconnect the air supply.
2. For cleaning and lubrication dismantle the cover ❶ and take out the clamp foot mechanism ❷. Remove material waste from the clamping area.
3. Open the needle bar cover ❸ and clean the guides ❹ and thread draw off ❺ from thread waste.
4. Clean the sewing mechanism - throatplate and loopers from fabric and thread waste.
5. Lubricate the machine as in section F 4.

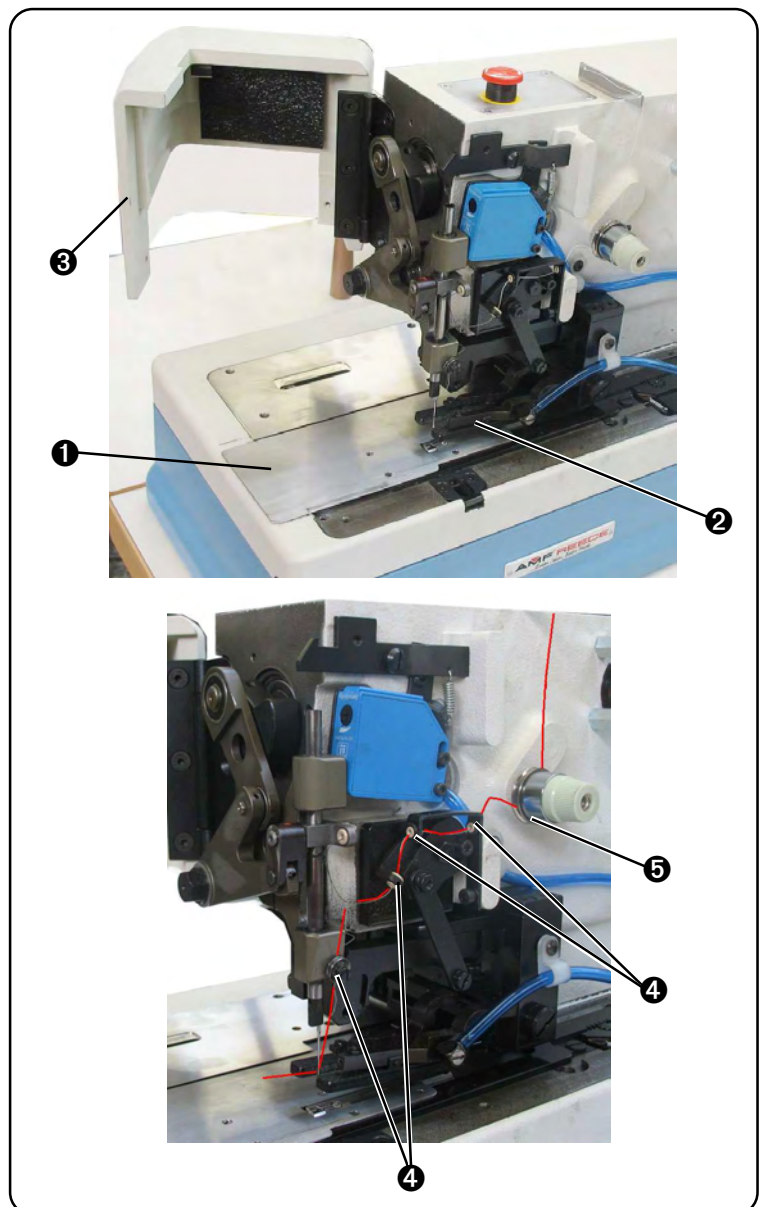

## F - MACHINE MAINTENANCE

6. Take out the filter cover **6** with the cleaning pad **7**. Beat or Hoover the pad. In case of severe fouling, wash the pad in washing liquid. Do the same maintenance with the back filter.

7. Maintenance of the filter and regulator

**Filter jar 8** – the polycarbonate filter jar must not in any case come into contact with synthetic oil, thinning agent, coal-oil, or other aroma hydrocarbon. For cleaning purposes, use neutral cleaning agents only.

**Automatic condensate separator** – maximal length of the condensate drain can be 5 m. It must be placed in the way so that the condensates can continually drain away.

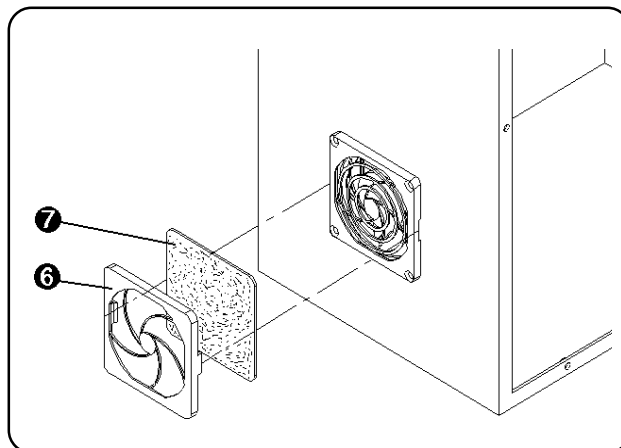

If the device does not work:

- check, if the input pressure is bigger than the output pressure set
- check the cleanness of the valve seating
- check, if the spring or membrane are not damaged
- check out the direction of air flow

### Exchange of the filter pad **9**

Conditions

- decline of flow supply
- sudden drop of pressure
- if the pressure drops onto 0.7 bars
- after a year of operation (in case it has not been changed)

- unscrew the filter jar **8**
- take out the filter pad **9** with the rectifier disk **10**
- remove the old filter pad and replace it with a new one
- fit the rectifier disk **10** into the new filter pad **9** and put both back in place
- screw the filter jar back in

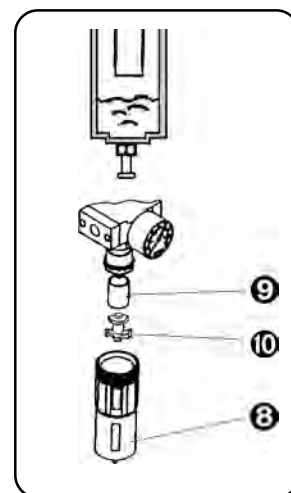



8. Check the mechanisms visually, especially the area of the sewing mechanism.

9. Once the maintenance and visual checking is completed, put the clamping foot mechanism back in place.

## F - MACHINE MAINTENANCE

### 2. LIST OF REGULAR SERVICES

<i>1x day (8 hours)</i>	cleaning sewing devices and machine frame Lubrication of mechanisms – see section F4.
<i>1x week (40 hours)</i>	visual checking of internal and external mechanisms Filling the oil tank with oil
<i>1x month (160 hours)</i>	checking plays in sewing mechanism drive Checking screw joins (keep below mentioned values) Checking condensate in regulator Checking fouling of cleaning pads of the control box.

Recommended values for srews tihtening (Nm):			
			
<b>M3</b>	0,5	0,6	0,8
<b>M4</b>	1,2	1,5	2,0
<b>M5</b>	2,5	3,0	4,0
<b>M6</b>	4,0	5,0	7,0
<b>M8</b>		8,0	16,0
<b>M10</b>		10,0	30,0

## F - MACHINE MAINTENANCE

### 3. SCHEME OF GROUP LUBRICATION

The machine is mainly equipped with needle bearings and ball bearings, which together with a single-circuit lubrication reduce the maintenance requirements.

**Circuit I** – the supply of lubrication for bite levers, feeding levers and loopers, and worm gear is in the body of the oil gauge. In case of a replacement of some distribution branches, the set of hoses and wicks can be ordered. For mounting, see the picture.

**Circuit I**

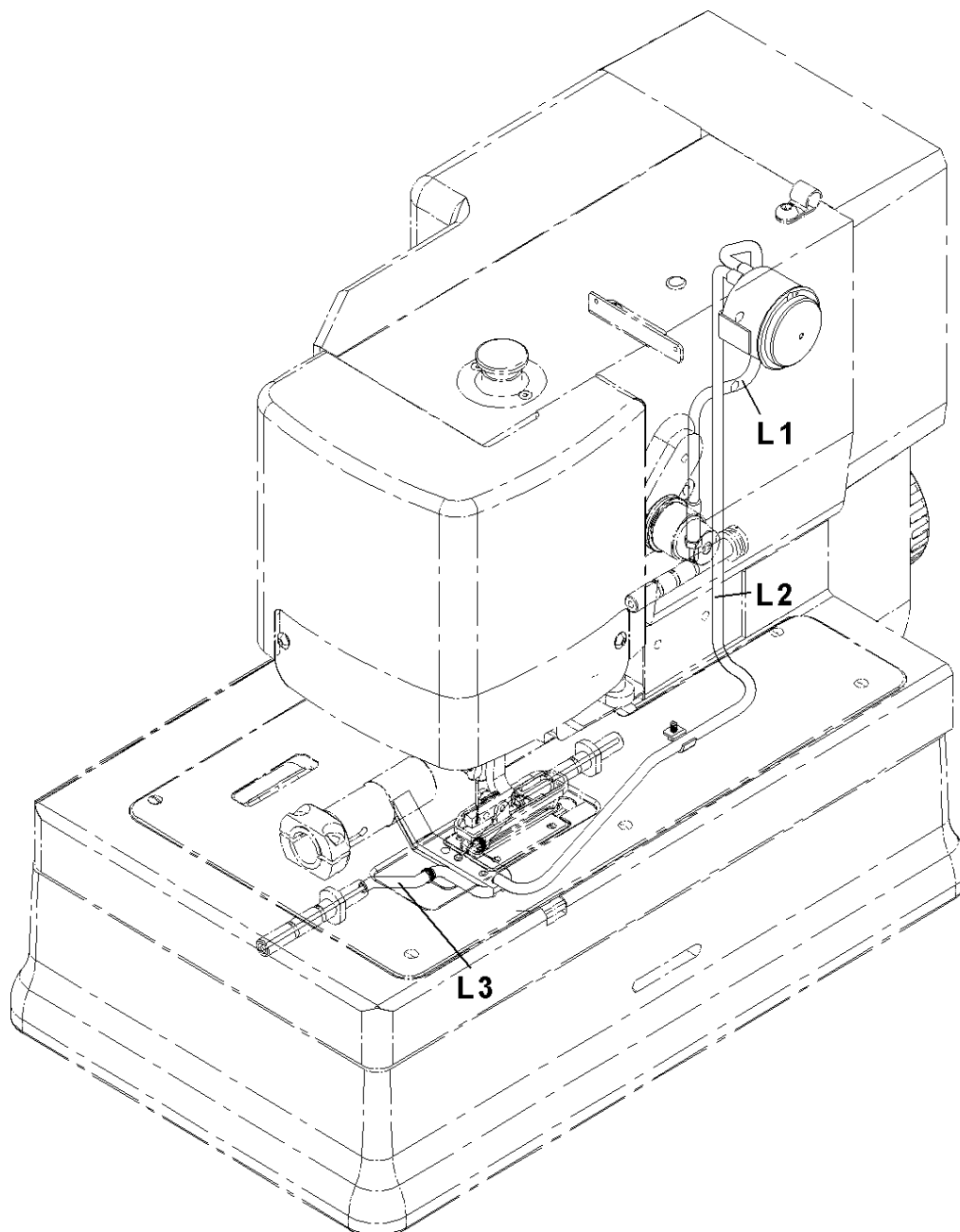

## F - MACHINE MAINTENANCE

### 4. MACHINE LUBRICATION

1. Before the machine is switched on for the first time, or after a long time without any operation, it is necessary to lubricate all areas said below. Lubricating oil ESSO TERESSO 32 or oil of similar characteristics can be used.
2. The quantity of oil in the oil tank **①** with an oil gauge is shown by a red mark. Too much oil can leak into the bedplate!
3. Fill the oil tank with approximately 10 cm<sup>3</sup> of oil through the filling hole **②**.
4. Needle bar mechanism **③** and draw off mechanism **④** can be lubricated after opening the needle bar cover **⑤**. It is also necessary to oil the main cam worm gear through the oiling opening **⑥**. Areas shown in the picture must be lubricated once (1x) a day (8 hours).

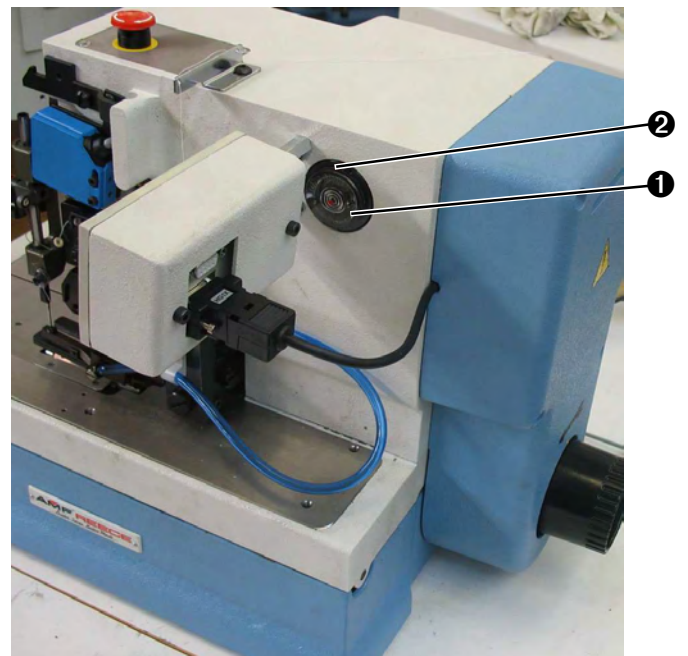

## F - MACHINE MAINTENANCE

5. Tilt the machine head onto the support pin and lubricate the areas shown in the picture.

- |   |               |   |                |
|---|---------------|---|----------------|
| ⑦ | loppers shaft | ⑪ | feeding cam    |
| ⑧ | feeding shaft | ⑫ | bite cam       |
| ⑨ | gearwheel     | ⑬ | trimming shaft |
| ⑩ | looper cam    |   |                |

Bring the machine head back into the operation position.

6. Once the machine is well oiled, it is efficient to run the machine at least 10 times with testing material in order to prevent sewn workpieces from possible stains and to wipe out visible oil remains on the machine.

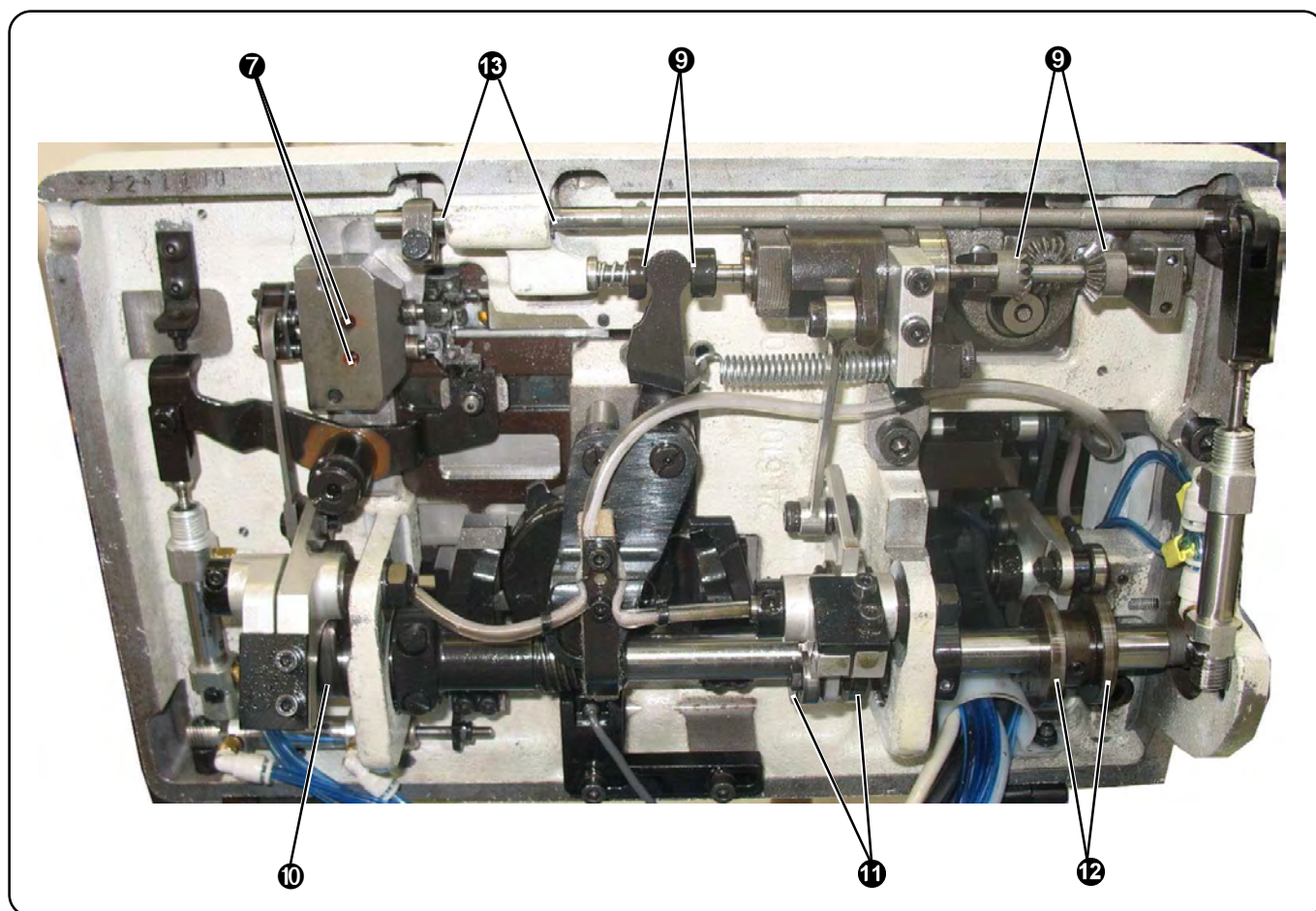

## F - MACHINE MAINTENANCE

---

### 5. DISPOSAL MEASURES

1. To ensure correct disposal of the machine following environmental measures, it is important to remove non-metal parts from the machine. Once such parts are taken out, it is necessary to partially dismantle the machine; remove covers, disassemble the machine arm and take it out of the frame.
2. Aluminum and hard aluminum parts, non-ferrous metal parts and plastic parts must be disposed separately.
3. Parts described *in ad 2* are marked in the spare parts manual as follows:
  - aluminum parts
  - non-ferrous metal parts
  - plastic and non metal alloys

*Note.:* parts assemblies containing aluminum parts, non-ferrous metal parts, steel parts and plastic parts must be dismantled first and then sorted into groups (●, ●●, ●●●).

# G - PNEUMATIC DIAGRAM

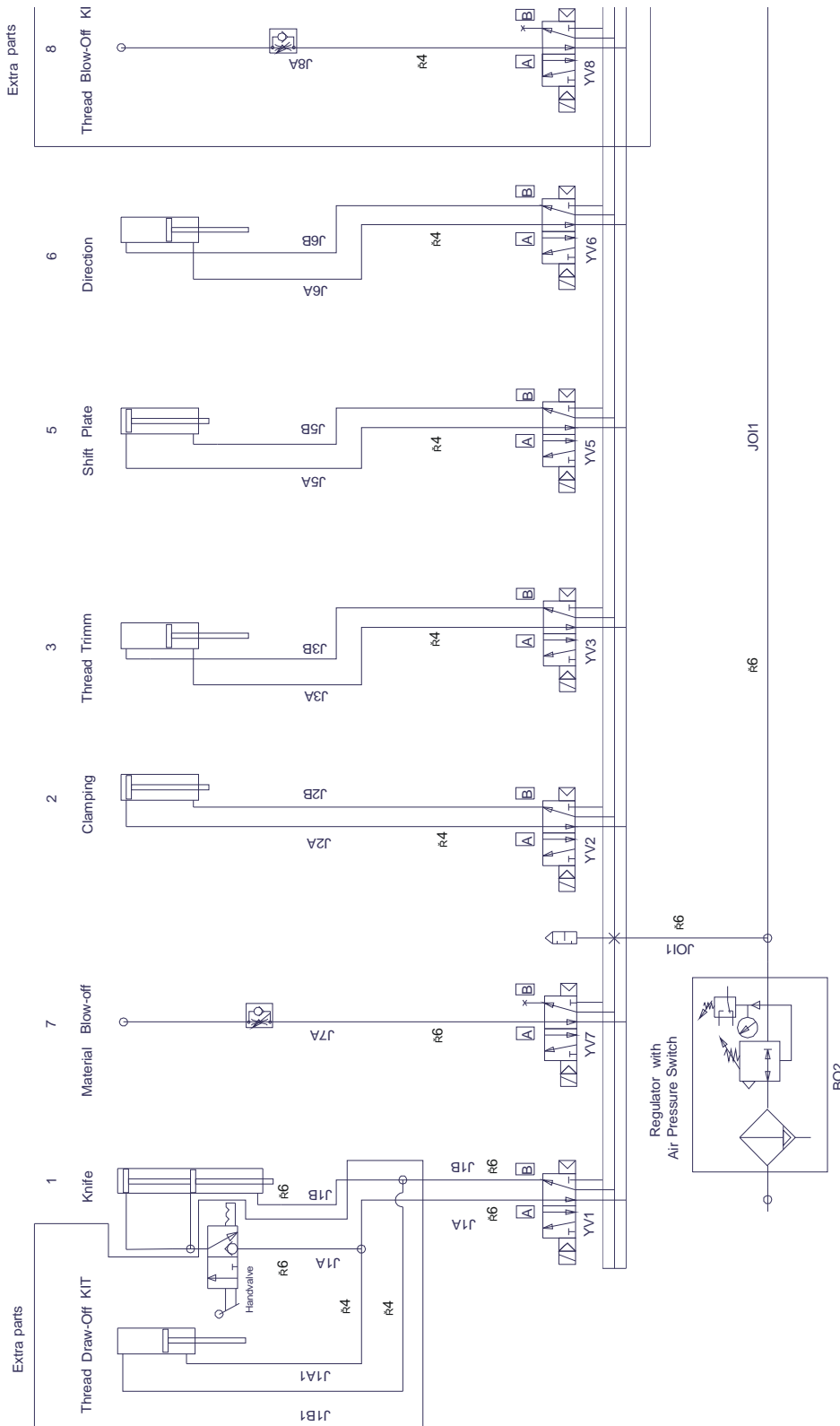



# H - ELECTRICAL DIAGRAM

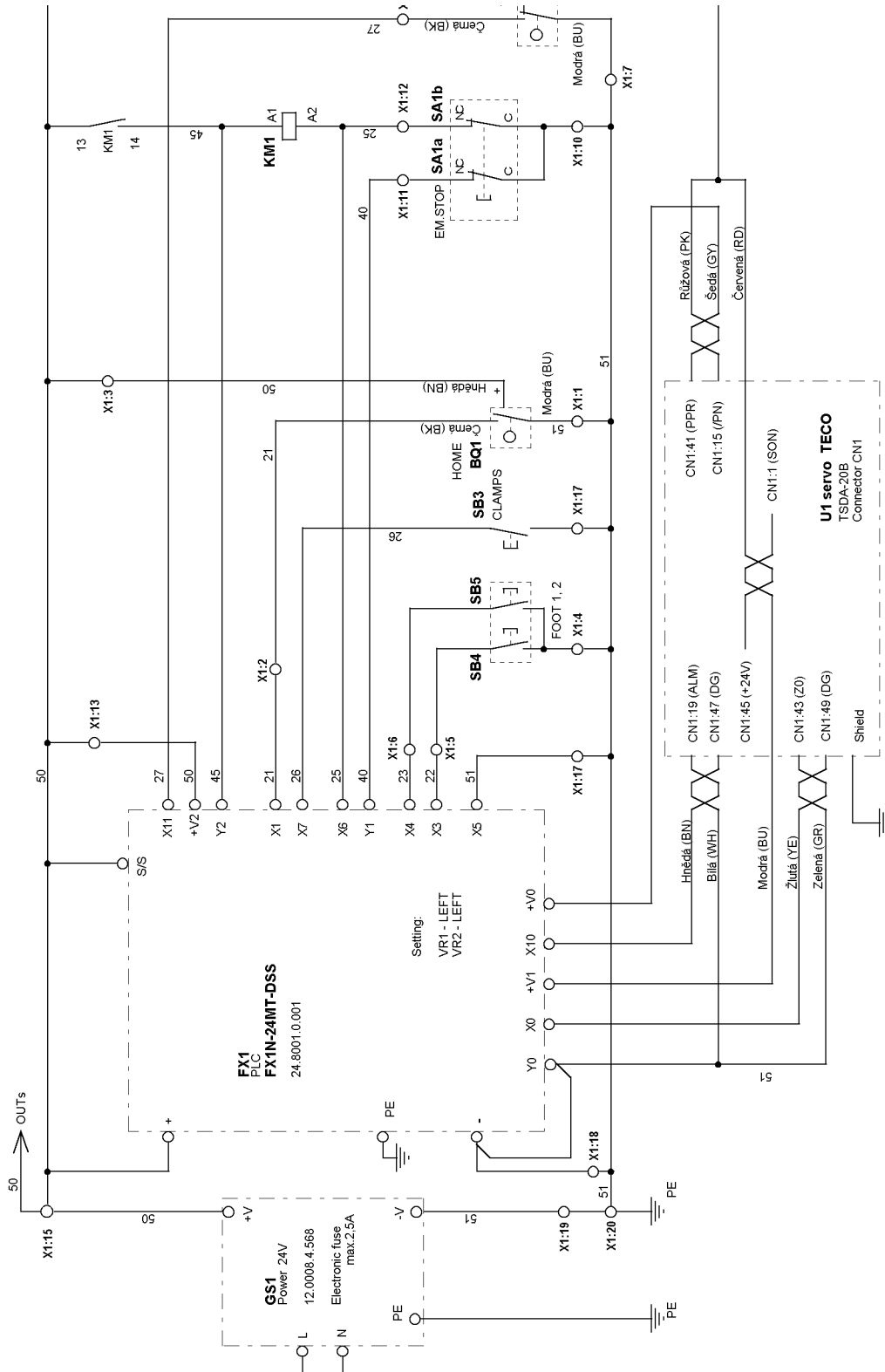



# H - ELECTRICAL DIAGRAM

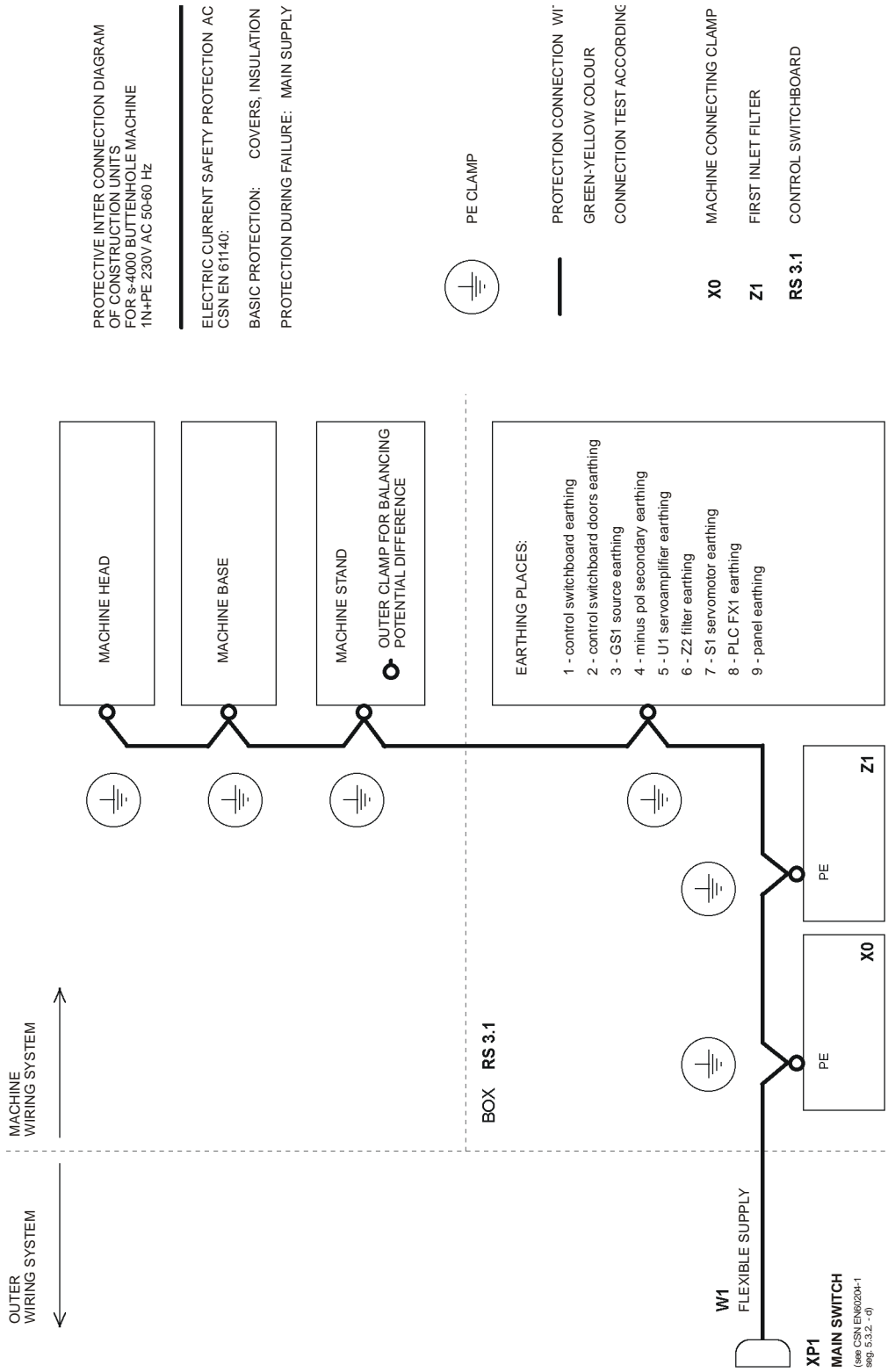

## **TROUBLESHOOTING - TABLE OF CONTENTS**

---

1. MECHANICAL FAULTS .....	2-2
2. CONTROL PANEL DISPLAY ERROR MESSAGES .....	2-5
3. SERVO ERROR MESSAGES .....	2-6
4. ELECTRICAL FAULTS .....	2-7

## TROUBLESHOOTING

### 1. MECHANICAL FAULTS

SYMPTOM	POSSIBLE CAUSE	PROBABLE SOLUTION
Thread breakage	Needle, looper, throat plate damaged	Change damaged parts
	Incorrect needle and sewing mechanism adjustment	Check the adjustment of the mechanisms
	Thread tension is too tight	Adjust correct tension
	Incorrect threading	See section C3 for checking.
	Thread guides polished incorrectly	Polish
	Poor thread quality	Replace thread
	Thread is too heavy for selected needle and throat plate	Use recommended thread sizes - see section A4
Machine fails to sew (Stitch skipping)	Needle, looper, throat plate damaged	Change damaged parts
	Incorrectly adjusted needle bar height	See section E4, point 2 for checking
	Incorrectly adjusted clearance between needle and throat plate	See section E5, point 3 for checking
	Incorrect loopers timing	See section E9 for checking
Machine sews in one spot	The home position of the clamp plate is adjusted incorrectly.	Adjust the stop - see section E11

## TROUBLESHOOTING

SYMPTOM	POSSIBLE CAUSE	PROBABLE SOLUTION
Stitch skip at the beginning of sewing	Needle, looper, throat plate damaged	Change damaged parts
	Needle thread end is too short	See section E15, point 1
	Incorrectly adjusted needle bar height	See section E4, point 2
	Incorrectly adjusted clearance between needle and throat plate	See section E5, point 3
	Incorrect loopers timing	See section E9
	Incorrectly adjusted clamp feet pressure	See section E 14, point 3
	The home position of the clamp plate is adjusted incorrectly.	See Section E10 to do the right adjustment
Stitch skip during sewing	Needle, looper, throat plate damaged	Change damaged parts
	Incorrectly adjusted needle bar height	See section E4, point 2
	Incorrectly adjusted clearance between needle and throat plate	See section E5, point 3
	Incorrect loopers timing	See section E9
	Incorrect thread tension adjustment	Adjust the tension correctly for section E16
	Incorrect threading	See section C3
	Thread loops are too small	See section E15 point 2
	Incorrectly adjusted clamp feet pressure	See section E14 point 3
	The clamp feet are adjusted too far from the sewing	See section E14 point 2

## TROUBLESHOOTING

SYMPTOM	POSSIBLE CAUSE	PROBABLE SOLUTION
Thread not trimmed at the end of the cycle	Trimming knife damaged	Replace
	Low air pressure at trimming cylinder	Check supply pressure
	Incorrect loopers timing	See section E9
	Incorrect setting of trimming delay	Change Trim delay parameter-D4
	Trimming length incorrectly set	Change Trim time parameter-D4
The fabric is not cut at the end of the cycle	The trimming knife is damaged	Re-sharpen or replace with a new one
	The edge of the stitching plate is damaged	Re-sharpen or replace with a new one
	Low pressure in the cylinder	Check the supply pressure
	The trimming mechanism to cut fabric adjusted incorrectly	Check with the instructions provided in Section E12
Sewing motor turns, machine does not sew	Belt broken or loose	See section E21 for changing
Machine sews continually, does not stop	Stopping sensor adjusted incorrectly	See section E20 for correct position adjustment
Zero pressure on regulator	Shut off valve closed	Open the shut off valve
Low air pressure	Filter element dirty	Change the filter element
	Air fitting or tubing obstruction	Check supply guides

## TROUBLESHOOTING

### 2. ERROR MESSAGES OF THE CONTROL PANEL DISPLAY

SYMPTOM	POSSIBLE CAUSE	PROBABLE SOLUTION
Low air pressure	Hand valve of the regulator switched off (if assembled)	Open the hand valve
	The air pressure in the air supply piping below 0.5 MPa	Increase the air pressure
Emergency stop, red LED light is ON	Emergency Stop button is switched on	Release the Emergency Stop button and press F6 key on the control panel
Service mode	The machine is in the service mode, motor is disconnected	Press F6 key on the control panel

### 3. ERROR MESSAGES OF THE SERVO

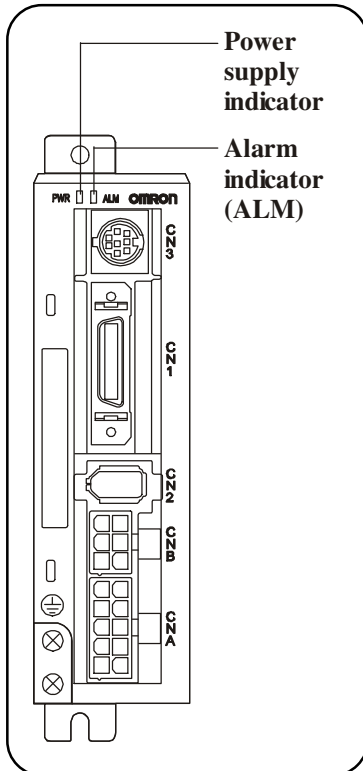

**PWR** - Power supply indication:

INDICATOR	STATUS
Lit green	Voltage is good
Lit orange - Flashes at a 1 sec. intervals	Varning - i.e.: - Exceeded power - Exceeded feed back - Default of inner fan
Lit red	Alarm - default

**ALM** - Default indication (Alarm indicator):

in case default appears, the indicator is switched on.

## TROUBLESHOOTING

### 4. ELECTRICAL FAULTS

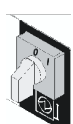
SYMPTOM	POSSIBLE CAUSE	PROBABLE SOLUTION
 <p>When switch <b>I</b>, neither the work light, display or the cooling fan operate</p>	No power supply	Check main power supply or voltage in the socket
	Fuse F1 failure	Replace fuse PN 12.0008.4.665
	Power switch QS1 damaged	Replace the switch 12.0008.4.835
	Power GS1 failure	Replace the power 12.0010.4.168
 <p>When switch <b>I</b>, display does not operate</p>	Cable from the display disconnected	Check the display connection
	Display or its control damaged	Replace display PN 24.8001.2.002 or control unit PLC 24.8001.0.001, call AMF Reece Service
<p>When sewing operation started, motor does not operate. Contactor KM1 switched on.</p>	Fuse F2 damaged	Replace fuse 12.0008.4.664
	Contactor KM1 damaged	Replace contactor 12.0008.4.833
	Servo U1 error or filter Z2 error	Call AMF Reece service or replace servo U1 (page 2-9) or filter Z2 (page 2-9)
	Error in sewing motor circuit	Switch the machine off for 1 minute, or restart it, alternatively call AMF Reece service
<p>When switching the machine on, the display shows a wrong model of the machine (i.e. S4000 ISBH instead of S4000 BH)</p>	Incorrect PLC setting	Set the potentiometer on the PLC as in the electric diagram – see Service chapter, Section H)

## TROUBLESHOOTING

SYMPTOM	POSSIBLE CAUSE	PROBABLE SOLUTION
When sewing operation started, motor fails to operate. Contactor KM1 switched off.	Make sure the machine is ready for operation	Press key F6 - see D1, point 6
	Contactor KM1 damaged	Replace contactor 12.0008.4.833
	Check the Emergency Stop button	Replace button 12.0008.4.563
	Control unit PLC error	Replace the control unit PLC 24.8001.2.001
The needle does not stop in the upper position	Position of the sensor BQ1 incorrectly adjusted	Adjust according to section E17
	Sensor BQ1 failure	Replace the sensor 06.2400.0.009
	Check the servo amplifier and servomotor	To set the servo amplifier - call AMF Reece service, alternatively replace motor (page 2-9) and servo amplifier (page 2-9)
When sewing operation started, air valves do no operate. The air pressure correct.	Fork is not fitted properly into connector X3	Check the connector X3 connection
	Control unit PLC error	Replace the control unit 24.8001.2.001
The machine does not respond to the signal from the sensor BQ3	The position of the sensor BQ3 adjusted incorrectly	Adjust correctly as in Section E23
	Faulty sensor BQ3	Replace the sensor 06.2400.0.701

## TROUBLESHOOTING

---

Notes: